

**SERVICE AND PARTS MANUAL  
FRYMASTER BIGLA30 SERIES  
LOV™ GAS FRYERS**



This equipment chapter is to be installed in the Fryer Section of the *Equipment Manual*.

**FOR YOUR SAFETY**

Do Not Store or use gasoline or other flammable vapors and liquids in the vicinity of this or any other appliance.



MANUFACTURED  
BY

 **Frymaster**

 **Manitowoc**

8700 Line Avenue  
SHREVEPORT, LOUISIANA 71106  
PHONE: 1-318-865-1711  
TOLL FREE: 1-800-551-8633  
1-800-24 FRYER  
FAX: 1-318-688-2200



Frymaster, L.L.C. 8700 Line Avenue, Shreveport, LA 71106,  
TEL 318-865-1711 FAX (Parts) 318-688-2200 (Tech Support) 318-219-7135

PRINTED IN THE UNITED STATES

**SERVICE HOTLINE  
1-800-24-FRYER**

[www.frymaster.com](http://www.frymaster.com)

E-mail: [service@frymaster.com](mailto:service@frymaster.com)

SEPTEMBER 2011  
\* 8196316 \*

**NOTICE**

IF, DURING THE WARRANTY PERIOD, THE CUSTOMER USES A PART FOR THIS MANITOWOC FOOD SERVICE EQUIPMENT OTHER THAN AN UNMODIFIED NEW OR RECYCLED PART PURCHASED DIRECTLY FROM FRYMASTER DEAN, OR ANY OF ITS AUTHORIZED SERVICE CENTERS, AND/OR THE PART BEING USED IS MODIFIED FROM ITS ORIGINAL CONFIGURATION, THIS WARRANTY WILL BE VOID. FURTHER, FRYMASTER DEAN AND ITS AFFILIATES WILL NOT BE LIABLE FOR ANY CLAIMS, DAMAGES OR EXPENSES INCURRED BY THE CUSTOMER WHICH ARISE DIRECTLY OR INDIRECTLY, IN WHOLE OR IN PART, DUE TO THE INSTALLATION OF ANY MODIFIED PART AND/OR PART RECEIVED FROM AN UNAUTHORIZED SERVICE CENTER.

**NOTICE**

This appliance is intended for professional use only and is to be operated by qualified personnel only. A Frymaster DEAN Authorized Service Agency (ASA) or other qualified professional should perform installation, maintenance, and repairs. Installation, maintenance, or repairs by unqualified personnel may void the manufacturer's warranty.

**NOTICE**

This equipment must be installed in accordance with the appropriate national and local codes of the country and/or region in which the appliance is installed. Refer to the operators manual.

**NOTICE TO U.S. CUSTOMERS**

This equipment is to be installed in compliance with the basic plumbing code of the Building Officials and Code Administrators International, Inc. (BOCA) and the Food Service Sanitation Manual of the U.S. Food and Drug Administration.

**NOTICE**

Drawings and photos used in this manual are intended to illustrate operational, cleaning and technical procedures and may not conform to onsite management operational procedures.

**NOTICE TO OWNERS OF UNITS EQUIPPED WITH COMPUTERS**

**U.S.**

This device complies with Part 15 of the FCC rules. Operation is subject to the following two conditions: 1) This device may not cause harmful interference, and 2) This device must accept any interference received, including interference that may cause undesired operation. While this device is a verified Class A device, it has been shown to meet the Class B limits.

**CANADA**

This digital apparatus does not exceed the Class A or B limits for radio noise emissions as set out by the ICES-003 standard of the Canadian Department of Communications.

Cet appareil numerique n'emet pas de bruits radioelectriques depassany les limites de classe A et B prescrites dans la norme NMB-003 edictee par le Ministre des Communcations du Canada.

** WARNING**

To ensure the safe and efficient operation of the fryer and hood, the electrical plug for the 120-volt line, which powers the hood, must be fully engaged and locked in its pin and sleeve socket.

** DANGER**

No structural material on the fryer should be altered or removed to accommodate placement of the fryer under a hood. Questions? Call the Frymaster Dean Service Hotline at 1-800-551-8633.

**NOTICE**

The instructions in this manual for using a bulk oil system for filling and discarding oil are for an RTI system. These instructions may not be applicable to other bulk oil systems.

**⚠ WARNING**

After installation of a gas fryer and after any maintenance to the gas system of a gas fryer-manifold, valve, burners, etc. – check for gas leaks at all connections. Apply a thick soapy solution to all connections and ensure there are no bubbles. There should be no smell of gas.

**⚠ DANGER**

Improper installation, adjustment, maintenance or service, and unauthorized alterations or modifications can cause property damage, injury, or death. Read the installation, operating, and service instructions thoroughly before installing or servicing this equipment. Only qualified service personnel may convert this appliance to use a gas other than that for which it was originally configured.

**⚠ DANGER**

Adequate means must be provided to limit the movement of this appliance without depending upon the gas line connection. Single fryers equipped with legs must be stabilized by installing anchor straps. All fryers equipped with casters must be stabilized by installing restraining chains. If a flexible gas line is used, an additional restraining cable must be connected at all times when the fryer is in use.

**⚠ DANGER**

The front ledge of the fryer is not a step! Do not stand on the fryer. Serious injury can result from slips or contact with the hot oil.

**⚠ DANGER**

Do not store or use gasoline or other flammable liquids or vapors in the vicinity of this or any other appliance.

**⚠ DANGER**

Instructions to be followed in the event the operator smells gas or otherwise detects a gas leak must be posted in a prominent location. This information can be obtained from the local gas company or gas supplier.

**⚠ DANGER**

This product contains chemicals known to the state of California to cause cancer and/or birth defects or other reproductive harm.

Operation, installation, and servicing of this product could expose you to airborne particles of glasswool or ceramic fibers, crystalline silica, and/or carbon monoxide. Inhalation of airborne particles of glasswool or ceramic fibers is known to the State of California to cause cancer. Inhalation of carbon monoxide is known to the State of California to cause birth defects or other reproductive harm.

**⚠ DANGER**

The crumb tray in fryers equipped with a filter system must be emptied into a fireproof container at the end of frying operations each day. Some food particles can spontaneously combust if left soaking in certain shortening material.

**⚠ WARNING**

Do not bang fry baskets or other utensils on the fryer's joiner strip. The strip is present to seal the joint between the fry vessels. Banging fry baskets on the strip to dislodge shortening will distort the strip, adversely affecting its fit. It is designed for a tight fit and should only be removed for cleaning.

# BIGLA30 SERIES LOV™ GAS FRYERS

## TABLE OF CONTENTS

### CHAPTER 1: Service Procedures

|        |   |      |
|--------|---|------|
| 1.1    | Functional Description.....   | 1-1  |
| 1.2    | The Electronic Ignition System.....                                       | 1-1  |
| 1.3    | Interface Board.....  | 1-2  |
| 1.4    | Thermostats.....  | 1-4  |
| 1.5    | Accessing Fryers for Servicing.....                                       | 1-4  |
| 1.6    | Cleaning the Gas Valve Vent Tube.....                                     | 1-4  |
| 1.7    | Checking the Burner Manifold Gas Pressure.....                            | 1-5  |
| 1.8    | Measuring Flame Current.....  | 1-7  |
| 1.9    | Replacing Fryer Components.....   | 1-7  |
| 1.9.1  | Replacing the Computer or the Computer Wiring Harness.....                | 1-7  |
| 1.9.2  | Replacing the Temperature Probe or High-Limit Thermostat.....             | 1-8  |
| 1.9.3  | Replacing the Interface Board.....  | 1-8  |
| 1.9.4  | Replacing an Ignition Module.....   | 1-8  |
| 1.9.5  | Replacing an Ignitor Assembly.....  | 1-9  |
| 1.9.6  | Replacing or Cleaning a Combustion Air Blower.....                        | 1-9  |
| 1.9.7  | Adjusting the Air/Gas Mixture.....  | 1-10 |
| 1.9.8  | Replacing a Gas Valve.....  | 1-11 |
| 1.9.9  | Replacing a Burner Assembly.....  | 1-12 |
| 1.9.10 | Replacing the Filter Motor, Filter Pump, or Filter Pump.....              | 1-13 |
| 1.9.11 | Replacing the Frypot.....   | 1-13 |
| 1.9.12 | Replacing Frypot Insulation and/or Upper Burner Rails.....                | 1-14 |
| 1.10   | Troubleshooting and Problem Isolation.....                                | 1-17 |
| 1.10.1 | Heating (Ignition) Failure.....   | 1-18 |
| 1.10.2 | Improper Burner Function.....   | 1-18 |
| 1.10.3 | Improper Temperature Control.....   | 1-20 |
| 1.10.4 | Computer Malfunctions.....  | 1-20 |
| 1.10.5 | Filtration Malfunctions.....  | 1-20 |
| 1.10.6 | Leakage.....  | 1-21 |
| 1.11   | Troubleshooting Guides.....   | 1-21 |
| 1.11.1 | Troubleshooting the 24 VAC Circuit.....                                   | 1-21 |
| 1.11.2 | Troubleshooting the Gas Valve.....  | 1-23 |
| 1.11.3 | Troubleshooting the Temperature Probe.....                                | 1-24 |
| 1.11.4 | Replacing the Transformer or Filter Relay.....                            | 1-24 |
| 1.12   | Probe Resistance Chart.....   | 1-25 |
| 1.13   | ATO (Automatic Top-Off ) Service Procedures.....                          | 1-25 |
| 1.13.1 | ATO (Automatic Top-Off Troubleshooting).....                              | 1-25 |
| 1.13.2 | ATO (Automatic Top-Off Troubleshooting) Board Pins and Positions.....     | 1-27 |
| 1.13.3 | Replacing the ATO Board or Transformer.....                               | 1-28 |
| 1.13.4 | Replacing the ATO Pump or Solenoid.....                                   | 1-28 |
| 1.14   | MIB (Manual Interface Board) Service Procedures.....                      | 1-28 |
| 1.14.1 | Manually Draining, Refilling or Filtering Using the MIB Board.....        | 1-29 |
| 1.14.2 | MIB (Manual Interface Board) Troubleshooting.....                         | 1-30 |
| 1.14.3 | MIB (Manual Interface Board) Pin Positions and Harnesses.....             | 1-32 |
| 1.14.4 | MIB (Manual Interface Board) Display Characters.....                      | 1-33 |
| 1.14.5 | Replacing the MIB Board.....  | 1-33 |
| 1.14.6 | Control Power Reset Switch.....   | 1-33 |
| 1.15   | RTI Service Issues.....   | 1-34 |
| 1.15.1 | RTI MIB Tests.....  | 1-34 |
| 1.15.2 | RTI LOV™ Wiring with RTI Switchbox.....                                   | 1-35 |
| 1.15.3 | RTI Plumbing Schematic.....   | 1-35 |
| 1.15.4 | RTI LOV™ Test Quick Reference.....  | 1-36 |
| 1.16   | AIF (Automatic Intermittent Filtration) Service Procedures.....           | 1-38 |
| 1.16.1 | AIF (Automatic Intermittent Filtration) Troubleshooting.....              | 1-38 |
| 1.16.2 | AIF (Automatic Intermittent Filtration) Actuator Board Pin Positions..... | 1-39 |
| 1.16.3 | Replacing an AIF (Automatic Intermittent Filtration) Board.....           | 1-40 |

|                              |  |      |
|------------------------------|--|------|
| 1.16.4                       | Replacing a Linear Actuator.....                                 | 1-40 |
| 1.16.5                       | Replacing a Rotary Actuator.....                                 | 1-41 |
| 1.16.6                       | Oil Level Sensor.....  | 1-41 |
| 1.16.6.1                     | Oil Level Sensor Troubleshooting.....                            | 1-41 |
| 1.16.6.2                     | Oil Level Sensor Diagram.....                                    | 1-42 |
| 1.17                         | M3000 Computer Service Procedures.....                           | 1-42 |
| 1.17.1                       | M3000 Computer Troubleshooting.....                              | 1-42 |
| 1.17.2                       | M3000 Useful Codes and Passwords.....                            | 1-45 |
| 1.17.3                       | Tech Mode.....   | 1-45 |
| 1.17.4                       | Service Required Errors.....                                     | 1-46 |
| 1.17.5                       | Error Log Codes.....   | 1-46 |
| 1.17.6                       | M3000 Filter Error Flowchart.....                                | 1-47 |
| 1.17.7                       | Clogged Drain/Failed Oil Sensor Flowchart.....                   | 1-48 |
| 1.17.8                       | M3000 Menu Summary Tree.....                                     | 1-49 |
| 1.17.9                       | M3000 Board Pin Positions and Harnesses.....                     | 1-50 |
| 1.18                         | Loading and Updating Software Procedures.....                    | 1-51 |
| 1.19                         | Principal Wiring Connections.....                                | 1-52 |
| 1.20                         | Wiring Diagrams.....   | 1-53 |
| 1.20.1                       | Main BIGLA230.....   | 1-53 |
| 1.20.2                       | Main BIGLA330.....   | 1-54 |
| 1.20.3                       | Transformer / Filter Boxes.....                                  | 1-55 |
| 1.20.3.1                     | BIGLA230 and 430 Transformer/Filter Box (Domestic).....          | 1-55 |
| 1.20.3.2                     | BIGLA230 and 430 Transformer/Filter Box (International).....     | 1-56 |
| 1.20.3.3                     | BIGLA330 Transformer/Filter Box (Domestic).....                  | 1-57 |
| 1.20.3.4                     | BIGLA330 Transformer/Filter Box (International).....             | 1-58 |
| 1.21                         | Simplified Wiring Diagrams.....                                  | 1-59 |
| 1.21.1                       | BIGLA30 Series LOV™ Simplified Wiring.....                       | 1-59 |
| 1.21.2                       | BIGLA30 Series LOV Data Network Flowchart.....                   | 1-60 |
| 1.22                         | Alternate Time Delay Relay Wiring Diagrams.....                  | 1-61 |
| 1.23                         | Shortening Melting Unit Wiring Diagram.....                      | 1-62 |
| <b>CHAPTER 2: Parts List</b> |  |      |
| 2.1                          | Accessories.....   | 2-1  |
| 2.2                          | Doors, Sides, Flue Caps, Cap-N-Splash, Top Caps and Casters..... | 2-2  |
| 2.3                          | Drain Valves and Associated Parts.....                           | 2-3  |
| 2.3.1                        | Linear Actuator Drain Valves.....                                | 2-3  |
| 2.3.2                        | Rotary Actuator Drain Valve.....                                 | 2-3  |
| 2.4                          | Drain Tube Sections and Associated Parts.....                    | 2-4  |
| 2.5                          | Electronics and Electrical Components.....                       | 2-5  |
| 2.5.1                        | High-Limit Thermostat and Temperature Probe.....                 | 2-5  |
| 2.5.2                        | Component Boxes.....   | 2-5  |
| 2.5.3                        | Transformer Boxes.....   | 2-7  |
| 2.5.4                        | Computers and Associated Components.....                         | 2-8  |
| 2.6                          | Wiring.....  | 2-9  |
| 2.6.1                        | Main Wiring Harnesses.....                                       | 2-9  |
| 2.6.2                        | Miscellaneous Wiring.....  | 2-10 |
| 2.6.3                        | M3000, MIB, AIF and ATO Wiring Harnesses.....                    | 2-10 |
| 2.7                          | Frypots and Associated Components.....                           | 2-11 |
| 2.7.1                        | Full-Vat Frypot Components.....                                  | 2-11 |
| 2.7.2                        | Dual-Vat Frypot Components.....                                  | 2-13 |
| 2.7.3                        | Frypot Assemblies and Associated Parts.....                      | 2-15 |
| 2.7.3.1                      | Frypots with Linear Actuators.....                               | 2-15 |
| 2.7.3.2                      | Frypots with Rotary Actuators.....                               | 2-16 |
| 2.8                          | Oil Return Manifolds.....  | 2-17 |
| 2.9                          | Return Valves and Associated Components.....                     | 2-17 |
| 2.10                         | Gas Supply and Combustion System Components.....                 | 2-18 |
| 2.11                         | Gas Valves and Associated Components.....                        | 2-20 |
| 2.12                         | Filtration System Components.....                                | 2-22 |
| 2.13                         | Auto Intermittent Filtration Components.....                     | 2-23 |
| 2.13.1                       | LOV Indicator Light and MIB Assembly.....                        | 2-23 |

|        |  |      |
|--------|--|------|
| 2.13.2 | AIF (Automatic Intermittent Filtration) Linear Actuator Board Assembly .....   | 2-24 |
| 2.14   | ATO (Automatic Top-Off) Components .....                                       | 2-24 |
| 2.14.1 | JIB Cradle, JIB Cap and Pick-Up Assembly and ATO(Automatic Top-Off) Board..... | 2-24 |
| 2.14.2 | ATO Pump Assembly .....  | 2-25 |
| 2.14.3 | ATO Pump Assembly Larger Lines.....  | 2-26 |
| 2.14.4 | Shortening Melting Unit .....  | 2-27 |
| 2.15   | RTI System Components .....  | 2-28 |
| 2.15.1 | RTI Dispose Waste Valve and Test Box.....                                      | 2-28 |
| 2.15.2 | RTI Manifold and Accessories prior to Oct 2010 .....                           | 2-28 |
| 2.15.3 | RTI Manifold and Accessories after Oct 2010.....                               | 2-30 |

# BIGLA30 SERIES LOV™ GAS FRYERS

## CHAPTER 1: SERVICE PROCEDURES

### 1.1 Functional Description

BIGLA30 Series LOV™ gas fryers contain a welded stainless steel frypot that is directly heated by a high efficiency infrared burner system, requiring approximately 43% less energy than conventional burners to cook the same volume.

Self-contained combustion chambers (referred to as “burners”) are fitted into rails attached to the sides of the frypot, one on each side. Each combustion chamber is fitted with special ceramic tiles that are heated by the burning of a forced air/gas mixture. The tiles transfer heat to the frypot by means of infrared radiation, providing much more constant and uniform heat dispersion over the surface of the frypot than do conventional burners. Because less heat is lost to the atmosphere in the process, compared to “open-burner” designs, less fuel is required to achieve and maintain a given frypot temperature.

In full-vat units, gas flow to both of the burners is regulated by one electromechanical gas valve. In dual-vat units, each burner has its own valve. All fryers in this series are equipped with 24 VAC gas valve systems, and all are configured with electronic ignition.

### 1.2 The Electronic Ignition System

An ignition module mounted below the component box (located behind the control panel) is connected to an ignitor assembly at the burner. The ignition module performs four important functions: it provides fuse protection for the 24-volt circuit, provides an ignition spark, supplies voltage to the gas valve, and proofs the burner flame. The module contains a four second time delay circuit and a coil that activates the gas valve. Three types are in use. A closed-box design is used in most fryers, but in some fryers built for export, the module resembles an interface board. A single dual-spark module is used on current production full-vat fryers. All dual-vat fryers use two single-spark modules.

The ignitor assembly consists of a spark plug, an enrichment tube, and a flame sensor.

At start-up, the power switch is placed in the ON position, supplying approximately 12-volts DC to the heat-control circuitry in the computer and to one side of the heat relay coils on the interface board. If resistance in the temperature probe indicates the temperature in the frypot is below 180°F (82°C), the current flows through a melt cycle circuit where a timer switch alternately closes for six seconds and opens for 24 seconds. If the temperature is 180°F (82°C) or above, the current flows through a heat circuit, bypassing the timer switch. In either case, ground is supplied to the other leg of the heat relay coils, which closes electronic switches in the 24 VAC circuit to provide current to the ignition module. Circuitry in the ignition module sends 24 VAC to the gas valve via a normally closed high-limit switch, and an oil level sensor which is controlled by electronics inside an egg shaped housing. Simultaneously, the module causes the ignitor to spark for four seconds to light the burner. A flame sensor verifies the burner ignition by measuring the flow of microamps through the flame. If the burner does not light (or is extinguished), current to the ignition module is cut, the gas valve closes, and the ignition module “locks out” until the power switch is turned off and then back on. A probe monitors the temperature in the frypot. When the programmed setpoint temperature is reached, resistance in the probe causes the heat cycle circuitry in the computer to cut off current flow through the heat relay. This in turn cuts off the 24 VAC to the ignition module, causing the gas valve to close.

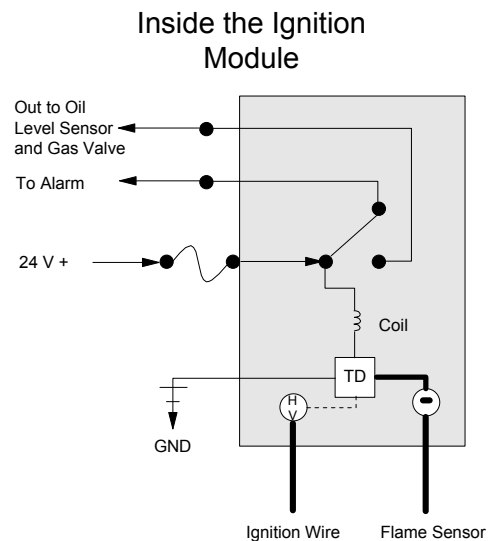

### 1.3 Interface Board

All fryers in this series have an interface board located in the component box behind the control panel. The interface board provides a link between the computer and the fryer's individual components without requiring excessive wiring, and allows the computer to execute commands from one central point.

K2 and K3 are double-pole-double throw (DPDT) relays that supply 24VAC to the ignition and gas valve circuits, as well as 120VAC to the blower motor. The relays on this board plug into sockets. If a relay fails, that relay can be replaced. K1 and K4 are single-pole-double throw (SPDT) relays that supply voltage to the oil level relay sensors and relay board.

LEDs (labeled D1 through D7) are arrayed around the board to assist in troubleshooting.

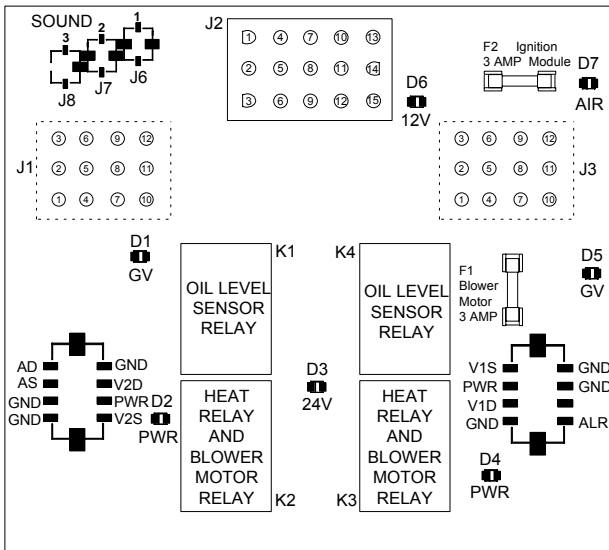

SMT INTERFACE BOARD KIT 826-2264 (106-6706)

| INTERFACE BOARD<br>LED DIAGNOSTIC LIGHTS |   |
|--|---|
| D1                                       | 24 VAC to left gas valve (dual vat only)        |
| D2                                       | 24 VAC to left ignition module (dual vat or CE) |
| D3                                       | 24 VAC from transformer                         |
| D4                                       | 24 VAC to right ignition module                 |
| D5                                       | 24 VAC to gas valve (right valve if dual vat)   |
| D6                                       | 12 VAC from transformer                         |
| D7                                       | CE and Japanese units only: air switch closed   |

**NOTE: Refer to Section 1.11.1 on page 1-22 for troubleshooting flowchart.**

**NOTE:** In full-vat fryers, the relay for the left side (K2) may not be present.

The chart on the following page illustrates current flow through the board, and the table at the top of page 1-4 identifies frequently used test points.

# INTERFACE BOARD

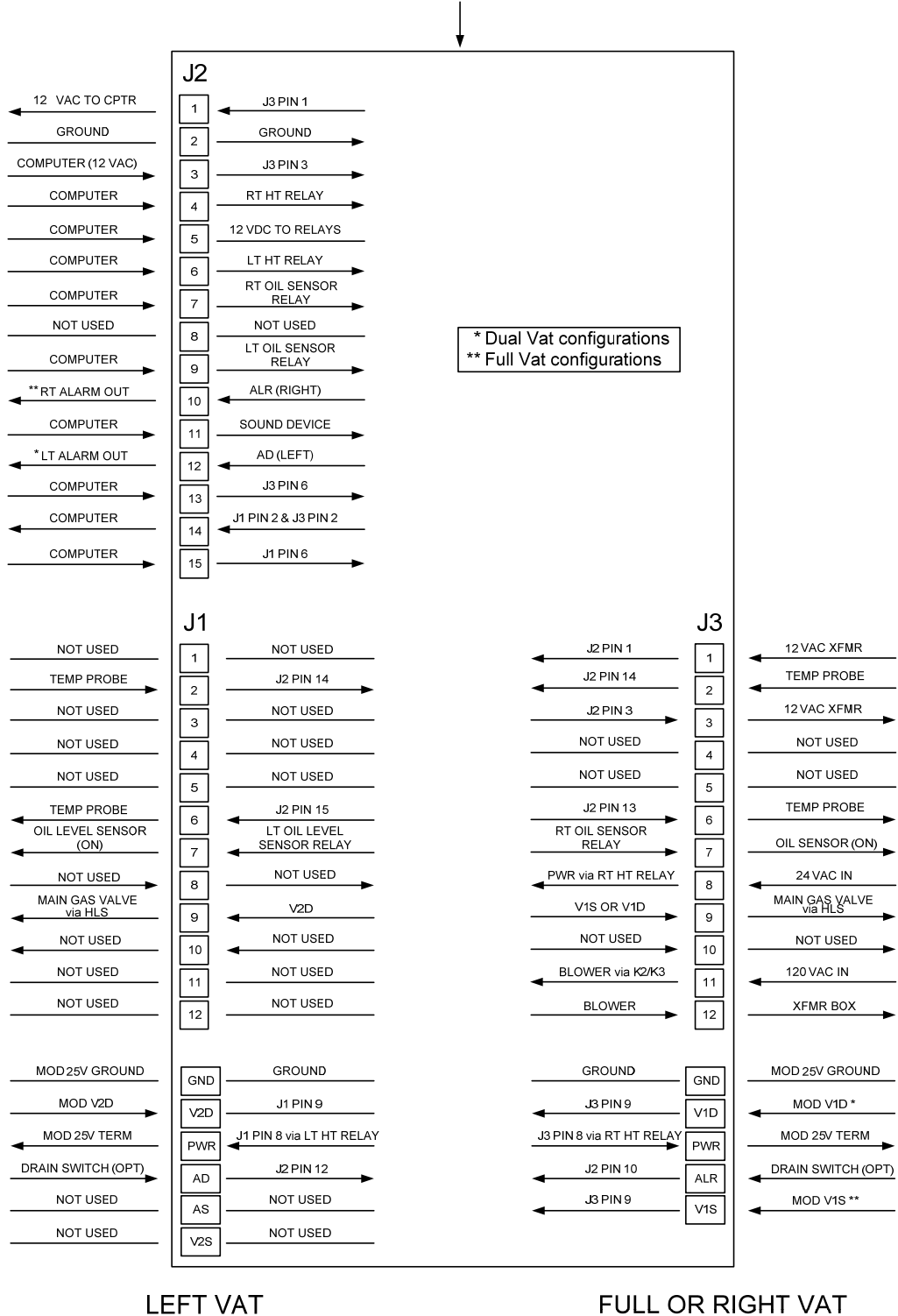

**CURRENT FLOW THROUGH INTERFACE BOARD  
106-6706 (SMT LOV SERIES APPLICATION)**

| FREQUENTLY USED TEST POINTS FOR INTERFACE BOARD 106-6706                  |               |                                   |         |
|---|---------------|-----------------------------------|---------|
| Test  | Meter Setting | Pins                              | Results |
| 12VAC Power to Controller   | 50VAC Scale   | 1 and 3 on J3 or J2               | 12-18   |
| 24VAC Power to Right Module   | 50VAC Scale   | 8 on J3 and GROUND                | 22-28   |
| 24VAC Power to Left Module (if present)                                   | 50VAC Scale   | 8 on J1 and GROUND                | 22-28   |
| 120 VAC Power   | 250VAC Scale  | 11 on J3 and GROUND               | 110-125 |
| 120 VAC Power to Blowers  | 250VAC Scale  | 12 on J3 and GROUND               | 110-125 |
| 24VAC Power to Full- or Right-vat High-Limit                              | 50VAC Scale   | 9 on J3 and GROUND                | 22-28   |
| 24VAC Power to Left High-Limit (if present)                               | 50VAC Scale   | 9 on J1 and GROUND                | 22-28   |
| Probe Resistance (Full- or Right-vat) *                                   | R x 1000 OHMS | 2 and 6 on J3 or 13 and 14 on J2  | **      |
| Probe Resistance (Left - if present) *                                    | R x 1000 OHMS | 2 and 6 on J1 or 14 and 15 on J2  | **      |
| Probe Isolation   | R x 1000 OHMS | 6 on J1 or J3 and GROUND          | ***     |
| High-Limit Continuity (Full- or Right-vat)                                | R x 1 OHM     | 9 on J3 and Wire 13C on Gas Valve | 0       |
| High-Limit Continuity (Left - if present)                                 | R x 1 OHM     | 9 on J1 and Wire 12C on Gas Valve | 0       |
| * Disconnect 20-pin harness from controller before testing probe circuit. |               |                                   |         |
| ** See Probe Resistance Chart at end of chapter.                          |               |                                   |         |
| *** 5 mega-Ohms or greater.   |               |                                   |         |

## 1.4 Thermostats

BIGLA30 Series LOV™ gas fryers have *temperature probes* located on the front centerline of each frypot (dual-vat frypots have two probes, one in each vat). In this type of thermostat, the probe resistance varies directly with the temperature. That is, as the temperature rises, so does resistance, at a rate of approximately 2 ohms for every 1° F. Circuitry in the computer monitors the probe resistance and controls burner firing when the resistance exceeds or falls below programmed temperatures (setpoints).

BIGLA30 Series LOV™ gas fryers are also equipped with a *high-limit thermostat*. In the event that the fryer fails to properly control the oil temperature, the high-limit thermostat prevents the fryer from overheating to the flash point. The high-limit thermostat acts as a normally closed power switch that opens when exposed to temperatures above 425°F to 450°F (218°C to 232°C). The different types of thermostats have different part numbers for CE and Non-CE models, and are not interchangeable.

## 1.5 Accessing Fryers for Servicing

### DANGER

**Moving a fryer filled with oil may cause spilling or splattering of the hot liquid. Follow the draining instructions in section 4.10.4 on page 4-16 in Chapter 4 of the BIGLA30 Installation and Operation Manual (P/N 819-6286) before attempting to relocate a fryer for servicing.**

1. Shut off the gas supply to the unit. Unplug the power cords. Disconnect the unit from the gas supply.
2. Remove any attached restraining devices and relocate the fryer for service accessibility.
3. After servicing is complete, reconnect the unit to the gas supply, reattach restraining devices, and plug in the electrical cords. **NOTE: To ensure the safe and efficient operation of the fryer and hood, the electrical plug for the 120-volt line, which powers the hood, must be fully engaged and locked in its pin and sleeve socket.**

## 1.6 Cleaning the Gas Valve Vent Tube

1. Set the fryer power switch and the gas valve to the OFF position.
2. Carefully unscrew the vent tube from the gas valve. **NOTE:** The vent tube may be straightened for ease of removal.
3. Pass a piece of ordinary binding wire (.052 inch diameter) through the tube to remove any obstruction.

4. Remove the wire and blow through the tube to ensure it is clear.
5. Reinstall the tube and bend it so that the opening is pointing downward.

## 1.7 Checking the Burner Manifold Gas Pressure

1. **On non-CE fryers only** ensure that the gas valve knob is in the OFF position.

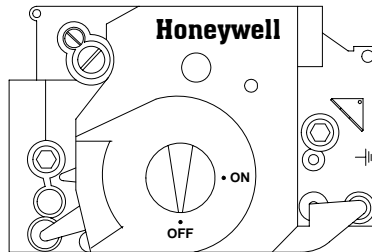

2. Remove the pressure tap plug from the gas valve assembly.

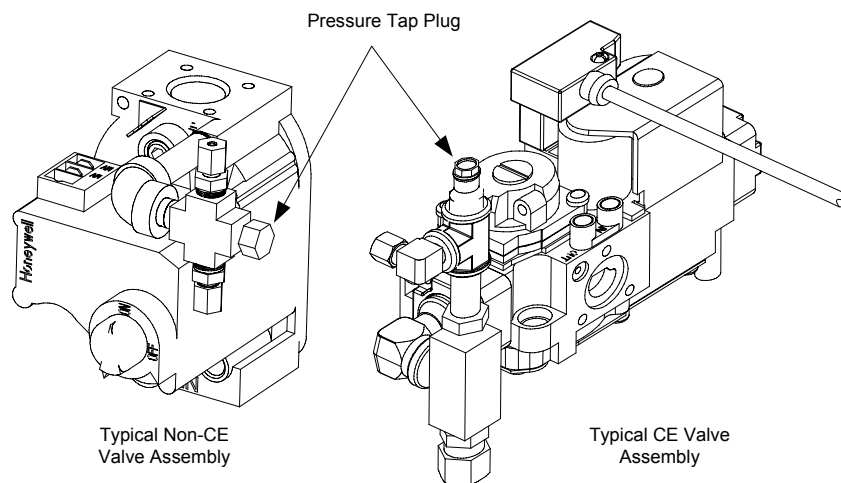

3. Insert the fitting for a gas pressure-measuring device into the pressure tap hole.
4. **On non-CE fryers only**, place the gas valve in the ON position
5. Place the fryer power switch in the ON position. When the burner has lit and burned steadily for at least one minute, compare the gas pressure reading to the pressure for the corresponding gas in the appropriate table on the following page. The tables list the burner manifold gas pressures for each of the gas types that can be used with this equipment.

| CE Standard<br>Burner Manifold Gas Pressures |                 |          |
|--|-----------------|----------|
| Gas  | Pressure (mbar) |          |
|  | Single Vat      | Dual Vat |
| Natural Gas Lacq (G20) under 20 mbar         | 7               | 7        |
| Natural Gas Gronique * (G25) under 25 mbar   | 10              | 10       |
| Natural Gas Gronique (G25) under 20 mbar     | 10              | 10       |
| Butane/Propane (G30) at 28/30 or 50 mbar     | 17              | 17       |
| Propane (G31) under 37 or 50 mbar            | 20              | 20       |

\* Belgian G25 = 7,0 mbar (single or dual)

| Non-CE Standard<br>Burner Manifold Gas Pressures |                       |
|--|-----------------------|
| Gas  | Pressure              |
| Natural  | 3" W.C.<br>0.73 kPa   |
| Propane  | 8.25" W.C.<br>2.5 kPa |

- To adjust the burner gas pressure, remove the cap from the gas valve regulator and adjust to the correct pressure.

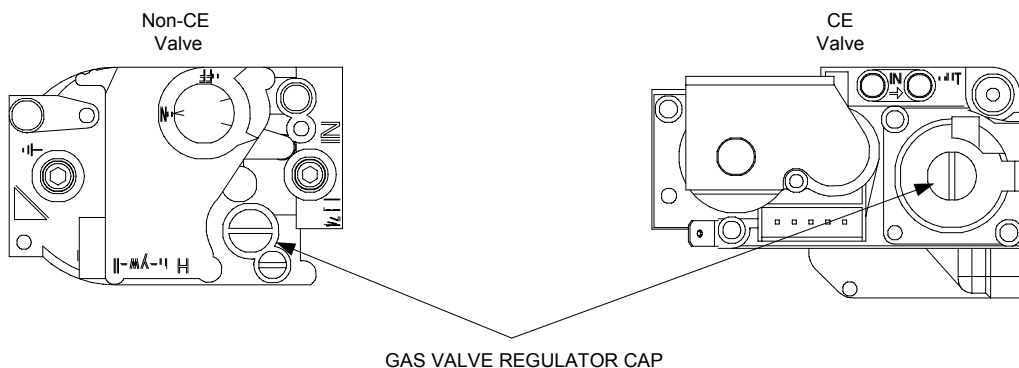

- Place the fryer power switch (and the gas valve in non-CE fryers) in the OFF position. Remove the fitting from the pressure tap hole and reinstall the pressure tap plug.

## 1.8 Measuring Flame Current

When the burner flame is properly adjusted, it will produce a current between 1.5  $\mu\text{A}$  and 2.5  $\mu\text{A}$ . Flame current is measured by placing a *microamp* (not milliamp) meter in series with the sensing wire on the ignitor. This is accomplished as follows:

- Place the fryer power switch in the OFF position.

2. Disconnect the sensing wire from one of the burner ignitors and connect it to the positive lead of the meter. Connect the negative lead of the meter to the terminal from which the sensing wire was removed.

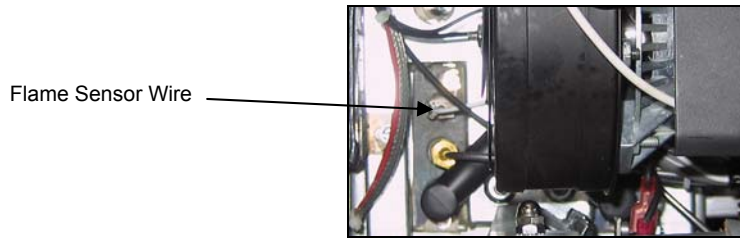

3. Place the fryer power switch in the ON position to light the burners. After the frypot temperature reaches 200°F (93°C), wait at least one minute before checking the reading. **NOTE:** The closer the unit is to normal operating temperature, the more accurate the reading will be.

## 1.9 Replacing Fryer Components

### 1.9.1 Replacing the Computer or the Computer Wiring Harnesses

1. Disconnect the fryer from the electrical power supply.
2. The computer bezel is held in place by tabs at the top and bottom. Slide the metal bezel up to disengage the lower tabs. Then slide the bezel down to disengage the upper tabs.
3. Remove the two screws from the upper corners of the computer. The computer is hinged at the bottom and will swing open from the top.
4. Unplug the wiring harnesses from the connectors on the back of the computer marking their position for reassembly and disconnect the grounding wires from the terminals. Remove the computer by lifting it from the hinged slots in the control panel frame.



5. Install the replacement computer. Reinstall the control panel assembly by reversing steps 1 thru 4.
6. Setup the computer following the instructions on page 4-9 in the Installation and Operation manual. Setup **MUST** be performed prior to readdress.
7. Once setup is complete on all replaced computers, CYCLE POWER TO ENTIRE FRYER SYSTEM. See section 1.14.6 to reset control power.
8. Check software version and if necessary update the software. If a software update was necessary, follow the instructions to update the software in section 1.18.

### 1.9.2 Replacing the Temperature Probe, ATO Probe, AIF Probe, Oil Level Sensor or High-Limit Thermostat

1. Disconnect the fryer from the electrical supply.
2. Drain cooking oil below the level of the probe or thermostat.
3. Lift up on the bezel to disengage the tabs on its lower edge from the control panel frame.
4. Remove the top two screws in the upper corners of the computer.
5. Swing the computer out from the top and allow it to rest on its hinge tabs.
6. Disconnect the computer wiring harness and ground wire from the back of the computer and remove the computer by lifting it from the hinge slots in the control panel frame.
7. Disconnect the ignition cables from the ignitors by grasping the boots and gently pulling toward you.
8. Disconnect the flame sensor wires from the flame sensors.
9. Disconnect the sound device lead from the interface board.

10. If working on the left frypot, cut the wire tie on the wiring bundle and disconnect the main wiring harness 15-pin connector.
11. Remove the component box mounting screws.
12. Rotate the top of the component box out of the frame and carefully pull it out enough to disconnect the wiring harness plug from the back of the box. This will leave one set of wires, enclosed in spiral wrap, connected to the component box.
13. Remove the box and set it atop the fryer to expose the temperature probe and high-limit thermostat.
14. Unscrew the probe or thermostat from the frypot.
15. Apply Loctite® PST56765 pipe thread sealant or equivalent to the replacement part threads and screw the replacement part into the frypot, torquing to 180 inch-pounds.
16. Connect the wires from the new component as follows:
  - a. If replacing a probe, use a pin pusher to disconnect (one at a time) the red and white leads from the connector and insert the corresponding leads from the new probe into the plug.
  - b. If replacing the high-limit thermostat, use a pin pusher to disconnect the lead running to the connector and insert the corresponding lead from the new thermostat.
  - c. Reverse steps 1 through 13 to complete the procedure.

### 1.9.3 Replacing the Interface Board

1. Perform steps 1 through 4 from section 1.9.1.
2. Disconnect the wires attached to the interface board, marking or making a note of the wires and terminals to facilitate reconnection.
3. Remove the nuts at each corner of the interface board and carefully pull it from the studs far enough to allow the connector on the back of the board to be disconnected, then remove the board from the box. When removing the board, be careful not to lose the spacers that fit over the studs behind the board.
4. Recover the relay(s) from the failed interface board and install on the replacement board.
5. Reverse the procedure to install the replacement board, being sure that the spacers behind the board are in place and the computer locator wire is attached to a stud.

### 1.9.4 Replacing an Ignition Module

1. Disconnect the fryer from the electrical supply.
2. Lift up on the bezel to disengage the tabs on its lower edge from the control panel frame.
3. Remove the top two screws in the upper corners of the computer.
4. Swing the computer out from the top and allow it to rest on its hinge tabs.
5. Loosen the nuts attached to the screws of the module. Slide the module towards the rear of the component box until the nuts drop through the keyholes.
6. Carefully rotate the module and pull forward. On some units it may be necessary to remove the blower.
7. Disconnect the wires from the ignition module, marking or making a note of the wires and terminals to facilitate reconnection.
8. Remove the screws from the module.
9. Move the screws and spacers to the new module.
10. Reverse the procedure to install the replacement module.

### 1.9.5 Replacing an Ignitor Assembly



**DANGER**

**Drain the frypot before proceeding further.**

1. Disconnect the fryer from the electrical supply.
2. Disconnect the flame sensor wire by carefully pulling its push-on terminal from the terminal strip on the ignitor. Disconnect the gas enrichment tube at the ignitor-end compression fitting. Disconnect the ignition cable from the ignitor by grasping its boot and gently pulling toward you. (See photo on the next page)

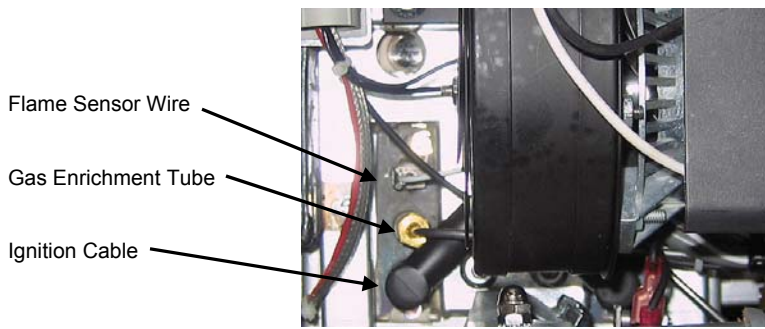

3. Remove the sheet metal screws securing the ignitor to the mounting plate and pull the ignitor from the fryer.
4. Reverse the procedure to install the replacement ignitor.

### 1.9.6 Replacing or Cleaning a Combustion Air Blower

1. Disconnect the blower wiring harness, remove the blower assembly mounting nuts, and remove the blower assembly from the fryer. If cleaning the motor, continue with Step 2; otherwise, install the replacement blower, reconnect the wiring harness, and then go to Step 6.

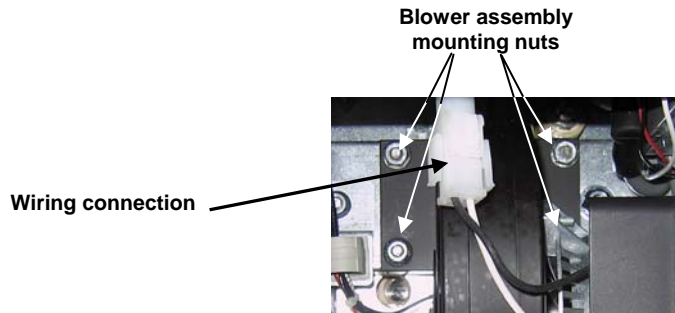

2. Remove the blower motor shield and separate the blower motor from the housing as shown in the illustration below.

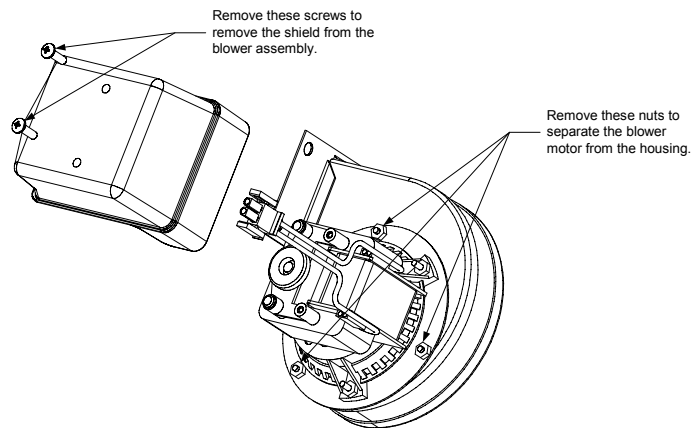

3. Wrap the motor with plastic wrap to prevent water from entering it. Spray degreaser or detergent on the blower wheel and the blower housing. Allow it to soak for five minutes. Rinse the wheel and housing with hot tap water, then dry with a clean cloth.

**NOTICE- Australia Only**

**The air pressure switch on the combustion blower should read: Full Vat units-122pa (0.5 inches W.C.) and for Split Vat units-180pa (0.72 inches W.C.).**

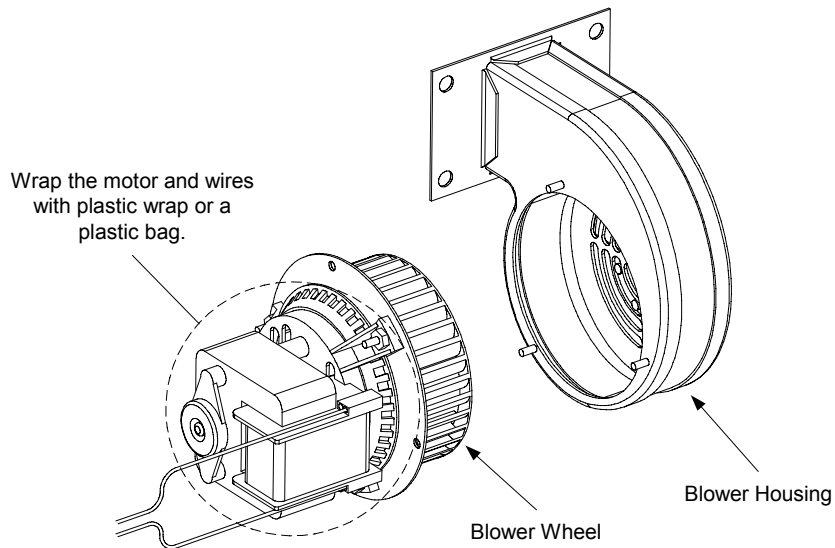

4. Remove the plastic wrap from the blower motor assembly. Reassemble the blower motor assembly and blower housing. Reinstall the blower shield.
5. Reinstall the blower assembly in the fryer and reconnect the wiring disconnected in Step 1.
6. Light the fryer in accordance with the procedure described in Chapter 3, Section 3.1.2 of the BIGLA30 Series LOV™ Gas Fryer Installation and Operation Manual (P/N 819-6286).
7. After the burners have been lit for at least 90 seconds, observe the flames through the burner viewing ports located on each side of the combustion air blower.

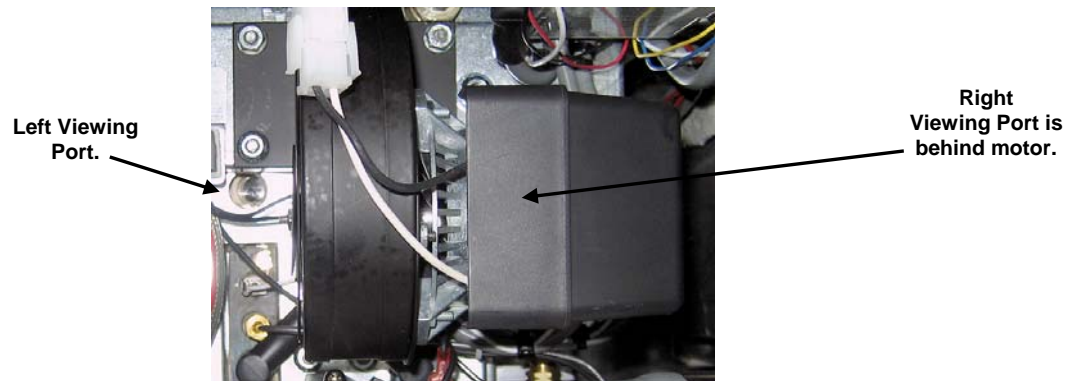

The air/gas mixture is properly adjusted when the burner manifold pressure is in accordance with the applicable table on page 1-6 and the burners display a bright orange-red glow. If a blue flame is observed or if there are dark spots on a burner face, the air/gas mixture requires adjustment.

**NOTE: Opening the air shutter too much may result in whistling. It should not be more than 1/3 open.**

### 1.9.7 Adjusting the Air/Gas Mixture

On the side of the blower housing opposite the motor is a shutter plate with a locking nut. Loosen the nut enough to allow the shutter to be moved, then adjust the position of the shutter to open or close the air intake opening until a bright orange-red glow is obtained, then close it slightly. Carefully hold the shutter in position and tighten the locking nut (see illustration on the following page).

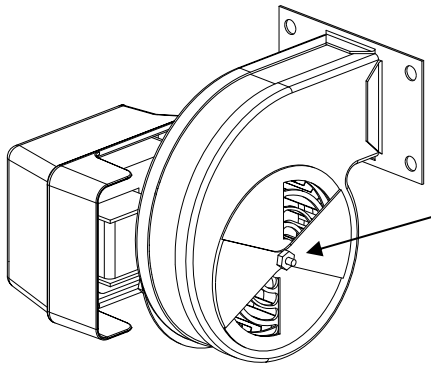

On non-CE blowers loosen this nut and rotate shutter to open or close air intake.

On CE blowers loosen both wing nuts and slide the shutter to adjust the air intake.

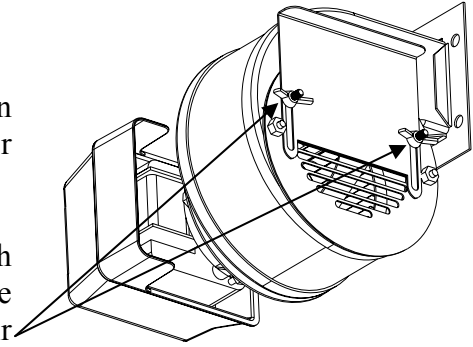

## 1.9.8 Replacing a Gas Valve

1. Disconnect fryer from electrical and gas supplies.
2. Disconnect the drain safety and high-limit thermostat wires from the gas valve. Mark each wire to facilitate reconnection.
3. Remove the vent tube (on non-CE fryers) and the enrichment tube fitting from the valve. Disconnect the flexible gas line(s).

**If replacing the left-most valve on any configuration, or the right valve on a two-fryer battery, follow the instructions below. If replacing valves in other positions, skip to “ALL OTHER VALVES.”**

- A. Remove the filter pan from the unit. Remove the door adjacent to the valve being replaced.
- B. Remove the screws on that attach the pan rails adjacent to the valve being replaced.
- C. Uncouple the pipe union and remove the gas valve and associated piping from the unit.
- D. Remove the fittings and associated piping from the failed valve and install them on the replacement valve using Loctite® PST56765 or equivalent pipe thread sealant.
- E. Reconnect the gas valve assembly to the fryer using Loctite® PST56765 or equivalent pipe thread sealant, and reattach the flexible gas line(s), enrichment tube(s), and the vent tube (on non-CE units). Reconnect the high-limit thermostat wires and drain safety wires to the valve.
- F. Reconnect the fryer to the gas supply and open the cut off valve. Apply a thick soapy solution of soapy water around each connection to check for gas leaks and ensure there are no bubbles. Eliminate any that are found. There should be no smell of gas.
- G. Position the pan rail assembly beneath the fryer and rest the rear end of the rail on the cabinet frame. Install the two nuts and bolts behind the front face of the rail, but do not tighten them. Install the nut and bolt at the rear end of the filter rail and tighten securely.
- H. Reattach the screws for the pan rails. Install the filter pan in the unit to make sure that all components are properly aligned.
- I. Reconnect the fryer to the electrical power supply and check for proper operation. When proper operation has been verified, reinstall the door removed in Step A.

## **ALL OTHER VALVES**

4. Carefully unscrew the valve from the manifold. **NOTE:** Some models may have the valve attached to the manifold by means of a pipe union. In such cases, remove the valve by uncoupling the union.
5. Remove all fittings from the old gas valve and install them on the replacement valve, using Loctite® PST56765 or equivalent pipe thread sealant.
6. Reconnect the gas valve assembly to the fryer using Loctite® PST56765 or equivalent pipe thread sealant, and reattach the flexible gas line(s), enrichment tube(s), and the vent tube (on non-CE units). Reconnect the high-limit thermostat wires and drain safety wires to the valve.
7. Reconnect the fryer to the gas supply and open the cut off valve. Apply a thick soapy solution of soapy water around each connection to check for gas leaks and ensure there are no bubbles. Eliminate any that are found. There should be no smell of gas.
8. Reconnect the fryer to the electrical power supply and check for proper operation.

### 1.9.9 Replacing a Burner Assembly on fryers built after Oct, 2010. For replacement of burners prior to that call the factory.

1. Disconnect the unit from the electrical and gas supplies.
2. Remove the gas line and enrichment tube using a 7/16" and 5/8" wrench from the front of the burner. It may be necessary to remove the MIB board in some locations.
3. Remove the elbow and tee off the bottom of the burner to ensure easier removal of the burner.
4. Remove the fryer back.
5. Remove the screws attaching the flue cap to the brace.
6. Remove the top cross brace in the back.
7. Remove the flue by removing the two screws in the rear and one screw in the front of the flue.
8. Remove all the screws on the flue collector and bend back the tabs and remove the collector.
9. Remove four screws on the collector insulation plate (see Figure 1).
10. Remove the four nuts and cover of the lower insulation retaining cover (see Figure 2).
11. Carefully remove the insulation being careful not to damage it.
12. Grasp the burner firmly and slide the burner out the rear of the fryer. Pull it toward you until it clears the burner channels, taking care not to damage the ceramic tiles in the process.
13. Slide the burner out the rear of the fryer.
14. Clean all debris from the burner channels and combustion area.
15. Inspect the upper and lower burner rails for cracked or burned out welds.
  - a. If the welds in the lower rail are cracked or burned out, the frypot must be replaced. Refer to Section 1.9.11 for procedure.
  - b. If the welds in the upper rail are cracked or burned out, the upper rail must be replaced. Refer to Section 1.9.12 for procedure.
16. Wrap a new insulating strip along the top, rear, and bottom edge of the burner.  
**NOTE:** Use P/N 826-0931 for full-vat frypots and P/N 826-0932 for dual-vat frypots.
17. Carefully slide the replacement burner into the rails starting at the top and lifting slightly up on the bottom (see Figure 3). Ensure that the insulation is not torn or damaged.
18. In reverse order reassemble insulation and holding plates.
19. Install flue collector.
20. Install the flue.
21. Install the cross brace ensuring the flue cap is secured to the brace.
22. Replace the fryer back.
23. Reattach the elbow, gas line and enrichment tubes to the front of the burner.
24. Fill the frypot with oil. Turn the fryer on, turn off or bypass the melt cycle, and operate the unit for at least 10 minutes.
25. Visually examine the burner flame. The color and intensity on both sides should be the same.
26. Use an inspection mirror to check for leaks in areas that cannot be directly observed.
27. If a leak is detected, tighten all the lower insulation retainer nuts, allow the frypot to run for five additional minutes, and repeat steps 25 and 26.
28. If the leak persists, use a rubber hammer and a small block of wood to tap the corners of the lower combustion chamber insulation retainers. Repeat steps 25 through 27. **Repeat this step until no leakage is detected.**



Figure 1



Figure 2

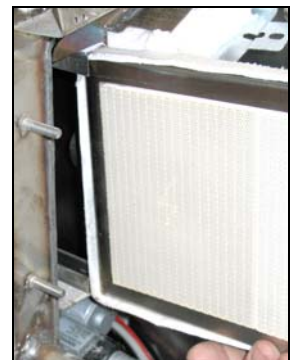

Figure 3

### 1.9.10 Replacing the Filter Motor or Filter Pump

1. Disconnect the unit from the electrical power supply.
2. Remove the filter pan from the unit.
3. Position a container beneath the oil return fitting at the front of the cabinet. Disconnect the flexible oil line from the fitting, allowing any residual oil to drain into the container.
4. At the rear of the fryer, unplug the left connector (as viewed from the rear of the fryer) from the transformer box.
5. Remove the four nuts and bolts attaching the motor mount to the rear motor mount support.
6. At the front of the fryer, remove the cover plate from the front of the motor and disconnect the motor wires.
7. Place a 1-foot (30.5-cm) length of wood (or similar support) beneath the motor mount near the front of the unit and remove the two remaining nuts and bolts attaching the motor mount to the front cabinet cross-brace.
8. Carefully remove the support and lower the motor mount to the floor, allowing the rear of the mount to slide forward and off the rear motor mount support.
9. Disconnect the return flexline from the pump. The motor and pump assembly can now be pulled from beneath the fryer and the failed component can be removed and replaced.
10. Position the replacement motor and pump assembly beneath the fryer and reconnect the oil return flexline to the pump. Lift the rear of the motor mount up and onto the rear motor mount support.
11. Lift the front of the motor mount up and support it with a 1-foot (30.5-cm) piece of wood or a similar support. Install but do not tighten the two nuts and bolts that attach the motor mount to the front cabinet cross-brace.
12. Install and tighten the four nuts and bolts that secure the motor mount to the rear motor mount support.
13. At the front of the fryer, tighten the two nuts and bolts at the front of the motor mount. Reconnect the motor power wires and reinstall the wiring cover plate.
14. Reconnect the oil return flexline and reinstall the filter pan.
15. Reconnect the unit to the electrical power supply, fill the frypots with oil and check for proper operation.

### 1.9.11 Replacing the Frypot

1. Disconnect the fryer from the electrical and gas supplies.
2. Remove the filter pan from the unit and drain one frypot at a time into a McDonald's Shortening Disposal Unit (MSDU) or other appropriate metal container using the drain function on the MIB board (see section 1.14 on page 29).



**DO NOT attempt to drain more than one full frypot or two split frypots into the MSDU at one time.**

3. Dismount the topcap by removing the screws on the bottom of each front corner and lifting the topcap straight up.
4. Remove the bezels by lifting them up to disengage the tabs along the lower edges from the slots in the control panel frame. Remove the top screws in the upper corners of the computer.
5. Grasp the upper edge of each computer and swing the computer downward. Unplug the computer wiring harness and grounding wire from the back of each computer.
6. Remove the computers by lifting them from the hinge slots in the control panel frame.
7. Disconnect the sound device wire from the interface board.
8. Disconnect the flame sensor wires by carefully pulling the push-on terminals from the terminal strips on the ignitors. Disconnect the gas enrichment tube at the ignitor-end compression fitting. Disconnect the ignition cables from the ignitors by grasping the boots and gently pulling toward you.

9. Remove the two mounting screws on each side of the component box and rotate the top of the box out of the frame. Carefully pull it out enough to disconnect the wiring harness connector from the back of the box. Cut any ties that prevent the box from being pulled out of the control panel frame.
10. Carefully pull the box clear of the frame and rest it on top of the fryer.
11. Using a pin pusher, remove the temperature probe, high-limit thermostat wires and RTD probe wires from the plugs or terminals, marking each wire to facilitate re-assembly.
12. Disconnect the actuators from the return and drain valves.
13. Remove the section(s) of drain from the drain valve(s) of the frypot to be removed.
14. Disconnect the gas lines from the burner orifices and ignitor assemblies.
15. Remove the frypot hold down bracket.
16. Remove the screws in the back panel and inside the flue cap at each end that secure the flue cap to the fryer and lift it clear of the fryer.
17. Disconnect the oil return line(s) from the frypot to be removed.
18. Disconnect all wiring from the AIF board.
19. Carefully lift the frypot from the fryer cabinet.
20. Remove the drain valve(s), temperature probe(s), high-limit thermostat(s), RTD probes, oil level sensor probes, AIF boards, actuators and ignitor assemblies. Inspect each of these components carefully and install them in the replacement frypot if they are in serviceable condition. Use Loctite<sup>®</sup> PST56765 sealant or equivalent on component threads.  
**NOTE:** Some servicers, based upon their experience, recommend that probes and thermostats be replaced whenever a frypot is replaced; however, this remains the customer's decision.
21. Reverse steps 1-20 to reassemble fryer.  
**NOTE:** Care should be taken not to over-torque nuts on frypots made of 400-series stainless steel, as this could tear the material. One turn past hand-tight is sufficient torque.
22. Perform steps 14 through 18 of Section 1.9.9 to ensure that there are no leaks in the burner insulation.

 **CAUTION**

**Before installing temperature probes, high-limit thermostats, RTD probes, oil level sensor probes, return valves and drain valves on replacement frypot, clean the threads and apply Loctite<sup>®</sup> PST56765 thread sealant or equivalent.**

### 1.9.12 Replacing Frypot Insulation and/or Upper Burner Rails

**NOTE:** Replacing the burner rails requires completely tearing down the frypot and installing new frypot insulation. Refer to the frypot exploded view below for component identification.

1. Remove the frypot per Section 1.9.11.
2. Remove the burner assemblies (1).
3. Remove insulation retainers and blanket insulation (2).
4. Remove the upper oil zone insulation bracket and upper oil zone insulation (3).
5. Remove the plenum (4).
6. Remove the front lower combustion chamber insulation retainer and insulation (5), and the front lower combustion chamber inner insulation retainer and insulation (6). **NOTE:** Full-vat units have two-piece insulation retainer and insulation components. Dual-vat units have one-piece components.
7. Remove the upper combustion chamber insulation retainer and insulation (7).
8. Remove the inner upper combustion chamber insulation retainer and insulation (8).
9. Remove the rear lower combustion chamber retainers, back, and insulation (9). **NOTE:** Full-vat units have two-piece backs and four retainers. Dual-vat units have one-piece backs and two retainers.
10. Remove the flue assembly (10).

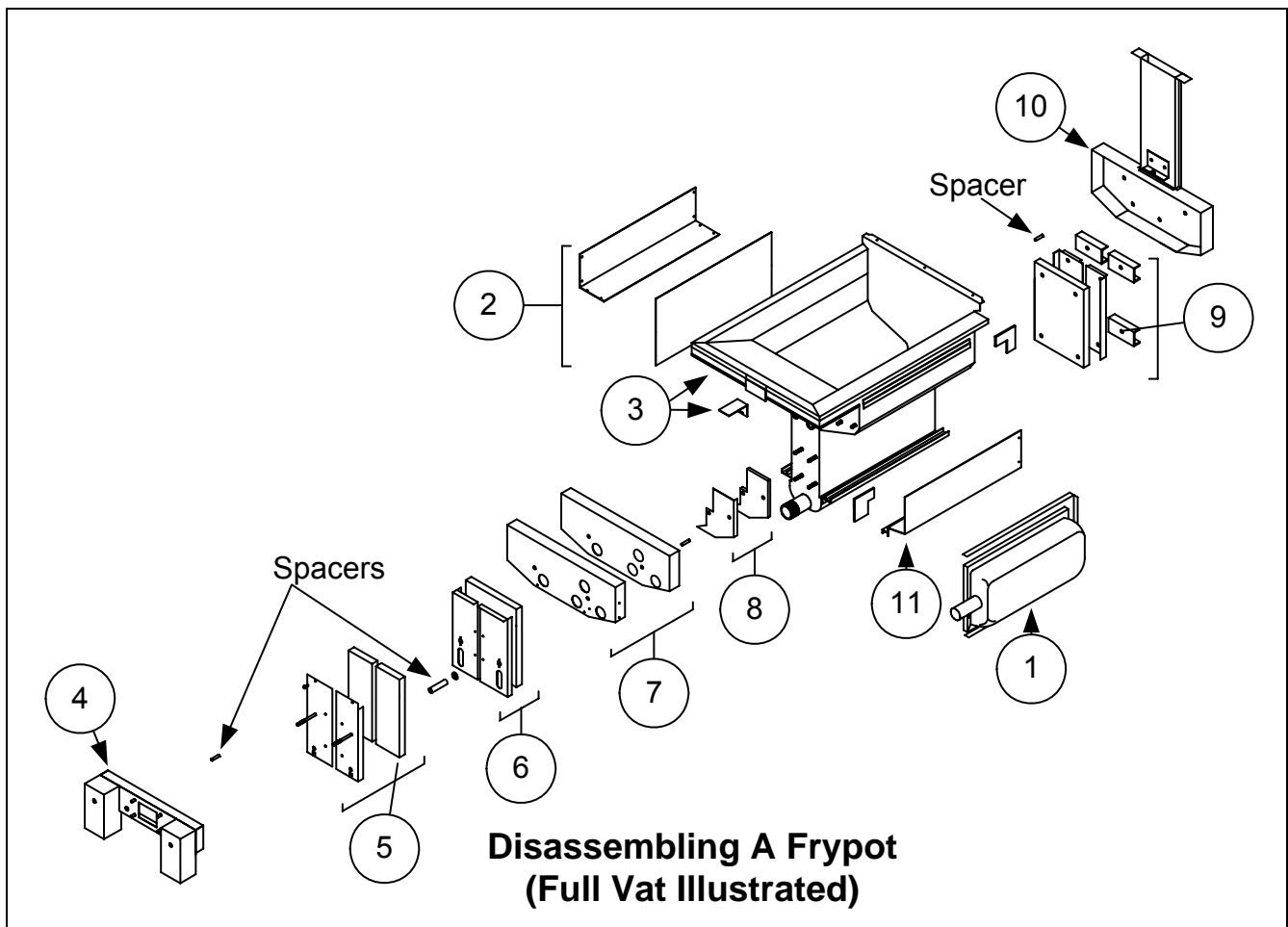

See page 1-17 for reassembly illustration.

11. Remove the upper burner rails (11). **NOTE:** For the following steps, refer to the frypot exploded view on page 1-16 for component identification.
12. Remove any residual insulation, sealant, and/or oil from the exterior of the frypot.
13. Place the “L” shaped pieces of the combustion chamber insulation (1) in the front and rear corners of both upper rail-retaining slots. (See page 1-16).
14. Using a mallet and short piece of wood, tap the corner tabs of the combustion chamber over the insulation to ensure a solid seal of the burner.
15. Install the upper burner rails (2) with the heat deflectors slanting toward the rear of the frypot. The rails will cover the “L” shaped pieces of combustion chamber insulation previously installed.
16. Place the upper inner combustion chamber insulation and insulation retainers (3) on the top two studs on each side of the front of the frypot and secure with ¼”-20 washer-nuts. *It is normal for the retainers to slice off the overhanging insulation.*
17. Place the lower rear combustion chamber insulation (4) on the lower four studs at the rear of the frypot.
18. Place one 1.625-inch tubular spacer (5) on each of the flue assembly (upper) studs at the rear of the frypot. **NOTE:** There are three different sizes of spacers. Verify the size to ensure the correct spacers are installed.
19. Press the flue assembly (6) over the burner rails. It may be necessary to use a rubber mallet or screwdriver to align the components. Use four ¼”-20 washer nuts to secure the flue assembly. **Do not tighten the retainer nuts at this point. They should be finger-tight only.** **NOTE:** The flue edge will cover one to two inches of the lower insulation.
20. Install the lower rear combustion chamber back(s) and retainer(s) (7) with the flanged edge(s) against the flue. Secure with ¼”-20 washer nuts. **NOTE:** Full-vat units have two-piece backs and four retainers. Dual-vat units come with one-piece backs and only two retainers.

21. Insert the burners (9) into the rails to ensure the rail spacing and alignments are correct. The burner should slide freely into and out of the rails. The upper rail can be bent slightly to increase or decrease tension on the burner and the edges of the slot can be closed or opened slightly to best fit the burner frame.
22. Carefully wrap a strip of burner insulation (8) tightly around the rear and sides of the burner frame (9), with the glass-tape side of the strip on the outside. **Do not use duct tape or adhesive to secure the strip to the burner frame.**
23. Align the burner to the burner rails while maintaining tension on the insulation strip. Insert the burner at a slight angle and begin pushing the burner slowly into the rails until it contacts the rear combustion chamber. The fit should be snug, but not excessively tight.
24. Verify that the burners are flush with the front edge of the burner rails. Remove the excess burner insulation by cutting with a knife or diagonal pliers. **Do not try to tear the insulation!**
25. Insert the upper front insulation (10) into its retainer (11), making sure that the holes in each piece are aligned with one another. Install the assembly with the insulation side toward the frypot and secure with ¼”-20 washer-nuts. **Do not over tighten.**
26. Place a washer on each of the four lower studs on the front of the frypot. Install the lower inner front insulation (12) with the rectangular openings toward the drain valve nipple. Install the lower inner front insulation retainer(s) (13). **NOTE:** Full-vat units have a two-piece insulation retainer. Dual-vat units have a one-piece retainer.
27. If necessary, replace the sight-glasses and insulation (14).
28. Place one washer and one 1.888-inch spacer (15) on each stud. **NOTE:** There are three different sizes of spacers. Verify the size to ensure the correct spacers are installed.
29. Insert the front lower insulation (16) into the front lower insulation retainer(s) (17) and install assembly on frypot. Secure with ¼”-20 washer-nuts. If frypot uses two retainers, connect them together with two ¼” self-tapping screws. **NOTE:** Full-vat units have a two-piece insulation retainer and two pieces of insulation. Dual-vat units have one-piece components.
30. Return to the rear of the frypot and fully tighten all washer-nuts.
31. Remove and replace the plenum gaskets (18).
32. Place a 0.938-inch spacer (19) on the plenum-mounting studs, and mount the plenum (20). Ensure the gaskets are clear of the burner tubes by pulling the plenum back slightly. Place a washer on each stud and secure plenum with ¼”-20 lock-nuts.
33. Install the upper oil-zone insulation (21) by pressing it under the upper combustion chamber metalwork. Secure the insulation with the bracket (22) and ¼” self-tapping screws.
34. Install the upper burner rail blanket insulation (23). Position any excess insulation toward the top of the frypot. Avoid overhang past the bottom of the upper burner rail. Overhang in this area will make future burner replacement more difficult.
35. Cover the insulation with the insulation retainer (24), and secure with ¼” self-tapping screws.
36. Reinstall probes, drain valves, AIF boards, actuators, high-limit thermostats, and other pipe fittings using Loctite® PST56765 sealant or equivalent on the threads.

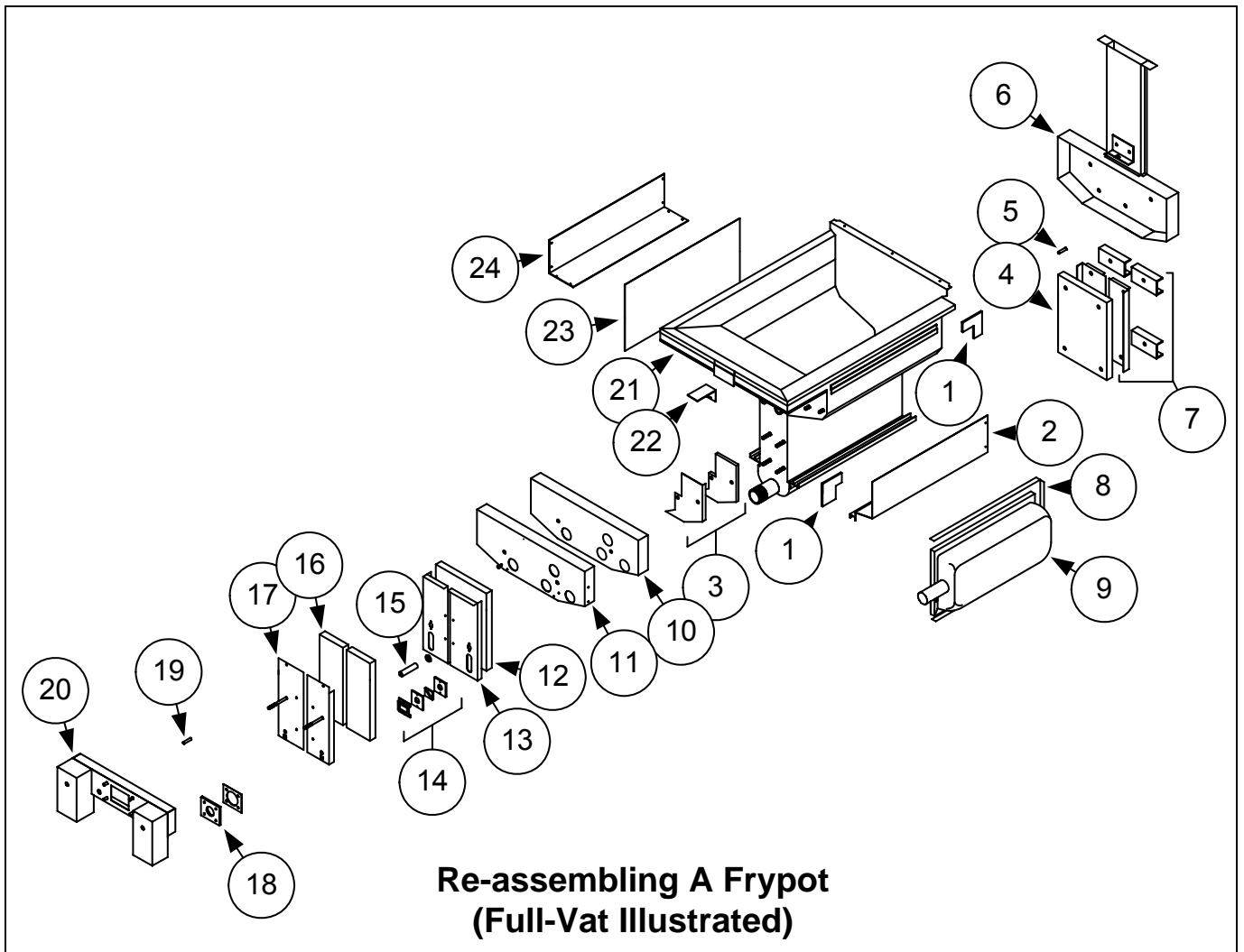

### 1.10 Troubleshooting and Problem Isolation

Because it is not feasible to attempt to include in this manual every conceivable problem or trouble condition that might be encountered, this section is intended to provide technicians with a general knowledge of the broad problem categories associated with this equipment, and the probable causes of each. With this knowledge, the technician should be able to isolate and correct any problem encountered.

Problems you are likely to encounter can be grouped into six categories:

1. Ignition failure
2. Improper burner function
3. Improper temperature control
4. Computer malfunctions
5. Filtration malfunctions
6. Leakage

The probable causes of each category are discussed in the following sections. A series of Troubleshooting Guides is also included at the end of the chapter to assist in solving some of the more common problems.

## 1.10.1 Heating (Ignition) Failure

Heating (ignition) failure occurs when the ignition module fails to sense a flame within the 4-second time delay period and locks out. When this happens, the module sends 24 VAC through the interface board alarm circuit to the computer.

M3000 computers display “**HEATING FAILURE.**”

The three primary reasons for heating failure, listed in order of probability, are problems related to:

1. Gas and/or electrical power supplies
2. Electronic circuits
3. Gas valve.

### PROBLEMS RELATED TO THE GAS AND/OR ELECTRICAL POWER SUPPLIES

The main indicators of this are that an entire battery of fryers fails to light and/or there are no indicator lights illuminated on the fryer experiencing heating failure. Verify that the quick disconnect fitting is properly connected, the fryer is plugged in with connector twisted and locked, the main gas supply valve is open, and the circuit breaker for the fryer electrical supply is not tripped.

### PROBLEMS RELATED TO THE ELECTRONIC CIRCUITS

If gas and electrical power are being supplied to the fryer, the next most likely cause of heating failure is a problem in the 24 VAC circuit. Verify that the oil level sensor is working properly. Refer to Section 1.11.1, **TROUBLESHOOTING THE 24 VAC CIRCUIT.**

Some typical causes of heating failure in this category include a defective sensing wire in the ignitor assembly, a defective module, a defective ignition wire, and a defective ignitor.

Occasionally, a heating failure situation occurs in which all components appear to be serviceable and the microamp reading is within specification, but the unit nevertheless goes into heating failure during operation. The probable cause in this case is an intermittent failure of an ignition module. When the unit is opened up for troubleshooting, the module cools down enough to operate correctly; however, when the unit is again closed up and placed back into service the module heats up and fails.

### PROBLEMS RELATED TO THE GAS VALVE

If the problem is not in the 24 VAC circuit, it is most likely in the gas valve, itself. Before replacing the gas valve, refer to Section 1.11.2 **TROUBLESHOOTING THE GAS VALVE.**

## 1.10.2 Improper Burner Function

With problems in this category, the burner ignites but exhibits abnormal characteristics such as “popping,” dark spots on the burner ceramics, fluctuating flame intensity, and flames shooting out of the flue.

“**Popping**” indicates delayed ignition. In this condition, the main gas valve is opening but the burner is not immediately lighting. When ignition does take place, the excess gas “explodes” into flame, rather than smoothly igniting.

The primary causes of popping are:

- Incorrect or fluctuating gas pressure
- Defective or incorrectly adjusted combustion air blower
- Inadequate make-up air
- Heat-damaged computer or ignition module
- Cracked ignitor or broken ignition wire
- Defective ignition module
- Cracked burner tile (typically causes a very loud pop).

If popping occurs only during peak operating hours, the problem may be incorrect or fluctuating gas pressure. Verify that the incoming gas pressure (pressure to the gas valve) is in accordance with the appropriate CE or Non-CE Standard found in Section 2.3 page 2-4 of the BIGLA30 Series LOV™ Gas Fryer Installation and Operation Manual (PN 819-6286), and that the pressure remains constant throughout all hours of usage. Refer to Section 1.7, **Checking the Burner Manifold Gas Pressure** in this manual for the procedure for checking the pressure of gas supplied to the burner.

If popping is consistent during all hours of operation, the most likely cause is an insufficient air supply. Check for “negative pressure” conditions in the kitchen area. If air is flowing into the kitchen area, this indicates that more air is being exhausted than is being replenished and the burners may be starved for air.

If the fryer’s gas and air supplies are correct, the problem is most likely with one of the electrical components. Examine the ignition module and computer for signs of melting, distortion, and/or discoloration due to excessive heat build-up in the fryer (this condition usually indicates improper flue performance). A melted or distorted ignition module is automatically suspect and should be replaced; however, unless the condition causing excessive heat is corrected, the problem is likely to recur.

Verify that the ignition wire is tightly connected at both ends and free of obvious signs of damage. Again, if damage is due to excessive heat in the fryer, that problem must also be corrected. Check for proper operation by disconnecting the wire from the ignitor (spark plug), inserting the tip of a screw driver into the terminal. With the insulated handle of the screwdriver, hold the shaft near the frame of the fryer as the power switch is placed in the ON position. A strong, blue spark should be generated for at least four seconds.



**DANGER**

**Make sure you are holding the insulated handle of the screwdriver and not the blade. The sparking charge is approximately 25,000 volts.**

Examine the ignitor (spark plug) for any signs of cracking. A cracked ignitor must be replaced.

If all other causes have been ruled out, examine the burner tiles for any signs of cracking. If cracking is found, the burner must be replaced.

*Fluctuating flame intensity* is normally caused by either improper or fluctuating incoming gas pressure, but may also be the result of variations in the kitchen atmosphere. Verify incoming gas pressure in the same way as for “popping,” discussed in the preceding paragraphs. Variations in the kitchen atmosphere are usually caused by air conditioning and/or ventilation units starting and stopping during the day. As they start and stop, the pressure in the kitchen may change from positive or neutral to negative, or vice versa. They may also cause changes in airflow patterns that may affect flame intensity.

*Dark spots on the burner tiles* are the result of an improper air/gas mixture. Adjust the combustion air blower to reduce the amount of air in the mixture to correct this problem.

*Flames shooting out of the flue* are usually an indication of negative pressure in the kitchen. Air is being sucked out of the burner enclosure and the flames are literally following the air. If negative pressure is not the cause, check for high burner manifold gas pressure in accordance with the procedures in Section 1.7.

An *excessively noisy burner*, especially with *flames visible above the flue opening*, may indicate that the gas pressure is too high, or it may simply be that the gas valve vent tube is blocked. If the incoming gas pressure is correct and the vent tube is unobstructed, the gas valve regulator is probably defective.

Occasionally a burner may apparently be operating correctly, but nevertheless the fryer has a *slow recovery rate* (the length of time required for the fryer to increase the oil temperature from 250°F to 300°F (121°C to 149°C)). The primary causes of this include an over-filled frypot, a dirty or out-of-adjustment combustion air blower, low burner manifold pressure, and/or damaged burner tiles. Adding oil to the frypot during the recovery process will also cause a slow recovery rate.

If these causes are ruled out, the probable cause is a misadjusted gas valve regulator. Refer to Section 1.7, **Checking the Burner Manifold Gas Pressure**, for the gas valve adjustment procedure.

### 1.10.3 Improper Temperature Control

Temperature control, including the melt cycle, is a function of several interrelated components, each of which must operate correctly. The principle component is the temperature probe. Other components include the interface board, the computer itself, and the ignition module.

Improper temperature control problems can be categorized into melt cycle problems and failure to control at setpoint problems.

### MELT CYCLE PROBLEMS

Initiation of the melt cycle with M3000 computers is automatic. Problems may originate from the computer itself, the temperature probe, or a malfunctioning heat relay on the interface board.

### FAILURE TO CONTROL AT SETPOINT

Problems in this category may be caused by the temperature probe, the interface board, or the computer.

### 1.10.4 Computer Malfunctions

#### RECOVERY TIME

*Recovery time* – is a method of measuring a fryer’s performance. Put simply, it is the time required for the fryer to increase the oil temperature from 250°F to 300°F (121°C to 149°C). This range is used as a standard since ambient kitchen temperatures can affect the test if lower ranges are used.

The M3000 computer performs the recovery test each time the fryer warms up. An operator can view the results of the test any time the fryer is above the 300°F (149°C) point by pressing the INFO button once when the fryer is on. The test results will be displayed in the computer’s LED panel in minutes and seconds. The maximum acceptable recovery time for BIGLA30 Series LOV™ gas fryers is two minutes and twenty-five seconds.

### 1.10.5 Filtration Malfunctions

The majority of filtration problems arise from operator error. One of the most common errors is placing the filter pad on the bottom of the filter pan rather than over the filter screen.

Whenever the complaint is “the pump is running, but no oil is being filtered,” check the installation of the filter pad, including that the correct size is being used. While you are checking the filter pad, verify that the O-rings on the filter pan suction tube are present and in good condition. Missing or worn O-rings will allow the pump to suck air and decrease its efficiency.

If the pump motor overheats, its thermal overload will trip and the motor will not start until it is reset. If the pump motor does not start, press the red reset switch located on the front of the motor. If the pump then starts, something caused the motor to overheat. It may be just that several frypots in a large battery of fryers were being filtered one after the other and the pump became hot. Letting the pump cool down for at least a half-hour is all that is required in this case. More often, the pump overheated for one of the following reasons:

- Shortening that remained in the pan after previous filtering solidified in the suction tube recess in the bottom of the pan or the suction tube, itself. Adding hot oil to the pan and waiting a few minutes will usually correct this problem. A flexible wire can be used to clean out the suction tube and the recess in the bottom of the pan. **NEVER** use compressed air to blow solidified shortening out of the suction tube!
- The operator attempted to filter oil that was not heated. Cold oil is thicker and causes the pump motor to work harder and overheat.

If the motor hums but the pump does not rotate, there is a blockage in the pump. Incorrectly sized or installed paper will allow food particles and sediment to pass through the filter pan and into the pump. When sediment enters the pump, the gears can bind up and cause the motor to overload, tripping the thermal overload. Solidified shortening in the pump will also cause it to seize, with similar results.

A pump seized by debris or hard shortening can usually be freed by manually moving the gears with a screwdriver or other instrument as

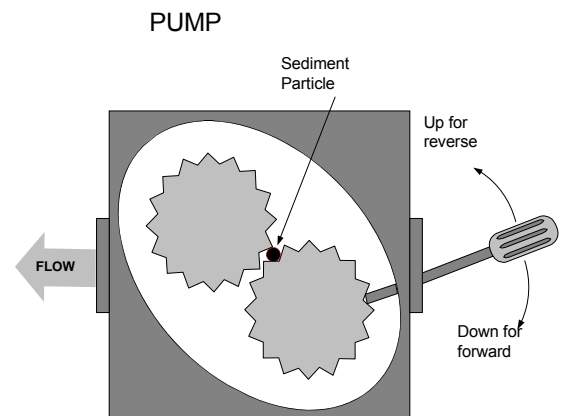

illustrated on the following page. **Make sure power to the pump motor is off before trying this.**

1. Disconnect power to the filter system.
2. Remove the input plumbing from the pump.
3. Use a screwdriver to manually turn the gears.
  - Turning the pump gears backwards will release a hard particle and allow its removal.
  - Turning the pump gears forward will push softer objects and solid shortening through the pump and allow free movement of the gears.

Filter pads that are installed incorrectly will also allow food particles and sediment to pass through and clog the suction tube recess on the bottom of the filter pan or the suction tube, itself. Particles large enough to block the suction tube recess or the suction tube may indicate that the crumb tray is not being used.

### 1.10.6 Leakage

Leakage of the frypot will usually be due to improperly sealed high-limit thermostats, RTD's, temperature probes, and drain fittings. When installed or replaced, each of these components must be sealed with Loctite<sup>®</sup> PST56765 sealant or equivalent to prevent leakage. In very rare cases, a leak may develop along one of the welded edges of the frypot. When this occurs, the frypot must be replaced.

If the sides or ends of the frypot are coated with oil, the most likely cause is spillage over the top of the frypot rather than leakage.

The clamps on the rubber boots that hold the drain tube sections together may loosen over time as the tubes expand and contract with heating and cooling during use. Also, the boot itself may be damaged. If the section of drain tube connected to the drain valve is removed for any reason, ensure that its rubber and clamps are in good condition and properly fitted around the drain tube when it is reinstalled. Also, check to ensure that the drain tube runs downward from the drain along its whole length and has no low points where oil may accumulate.

## 1.11 Troubleshooting Guides

The troubleshooting guides on the following pages are intended to assist service technicians in quickly isolating the probable causes of equipment malfunctions by following a logical, systematic process. An additional set of operator troubleshooting guides are contained in Chapter 7 of the BIGLA30 Series Installation and Operation Manual. It is suggested that service technicians thoroughly familiarize themselves with both sets.

### 1.11.1 Troubleshooting the 24 VAC Circuit

Prior to checking for problems associated with the 24 VAC circuit, ensure that the unit is connected to a power supply, the drain valve is fully closed, and the computer is on and is calling for heat (green dot appears under heat indicator and displays **LOW TEMP**).

**NOTE:** All voltage measurements must be made within **4 seconds** of the unit calling for heat. If unit does not fire within **4 seconds**, ignition modules will lock out and computer must be turned off, then on to reset.

The following processes will assist you in troubleshooting the 24 VAC circuit and ruling it out as a probable cause:

- **24 VAC is not present on the interface board J3 pin 9 (LED 5 (GV)) and, on dual units, on J1 pin 9 (LED 1 (GV)).**
  1. If LED 3 *is not* continually lit, the probable causes are a failed 24 VAC transformer or failed wiring between the transformer and interface board.
  2. If LED 3 *is* continually lit, check the right PWR terminal (LED 4) for 24 VAC. On dual units, also check the left PWR terminal (LED 2) for 24 VAC. Verify that the F2 fuse is not blown.
    - a. If 24 VAC *is not* present, the probable cause is a failed interface board, blown fuse or a defective heat relay.
    - b. If 24 VAC *is* present, check for 24 VAC on V1S (or V1D and V2D, if dual unit).
      - i. If 24 VAC *is not* present, check the fuses. If they are good, the probable causes are failed ignition module(s) or a failed interface board. Replace the questionable ignition module with one known to be good to isolate the cause.
      - ii. If 24 VAC *is* present, the probable cause is a failed interface board.

- **24 VAC is present on interface board J3 pin 9 (LED 5 (GV)) and, on dual units, on J1 pin 9 (LED 1 (GV)).**
  1. If 24 VAC is *not* present across the gas valve main coil (MV terminals), probable causes are an open high-limit thermostat or a failed wire between the interface board and gas valve. Be sure to check both valves on dual units.
    - a. Check continuity of high-limit thermostat. If it is zero, problem is in wiring.
  2. If 24 VAC is present across the gas valve main coil (MV terminals), the 24 VAC circuit is working and the problem may be with the gas valve. Be sure to check both valves on dual vat units.

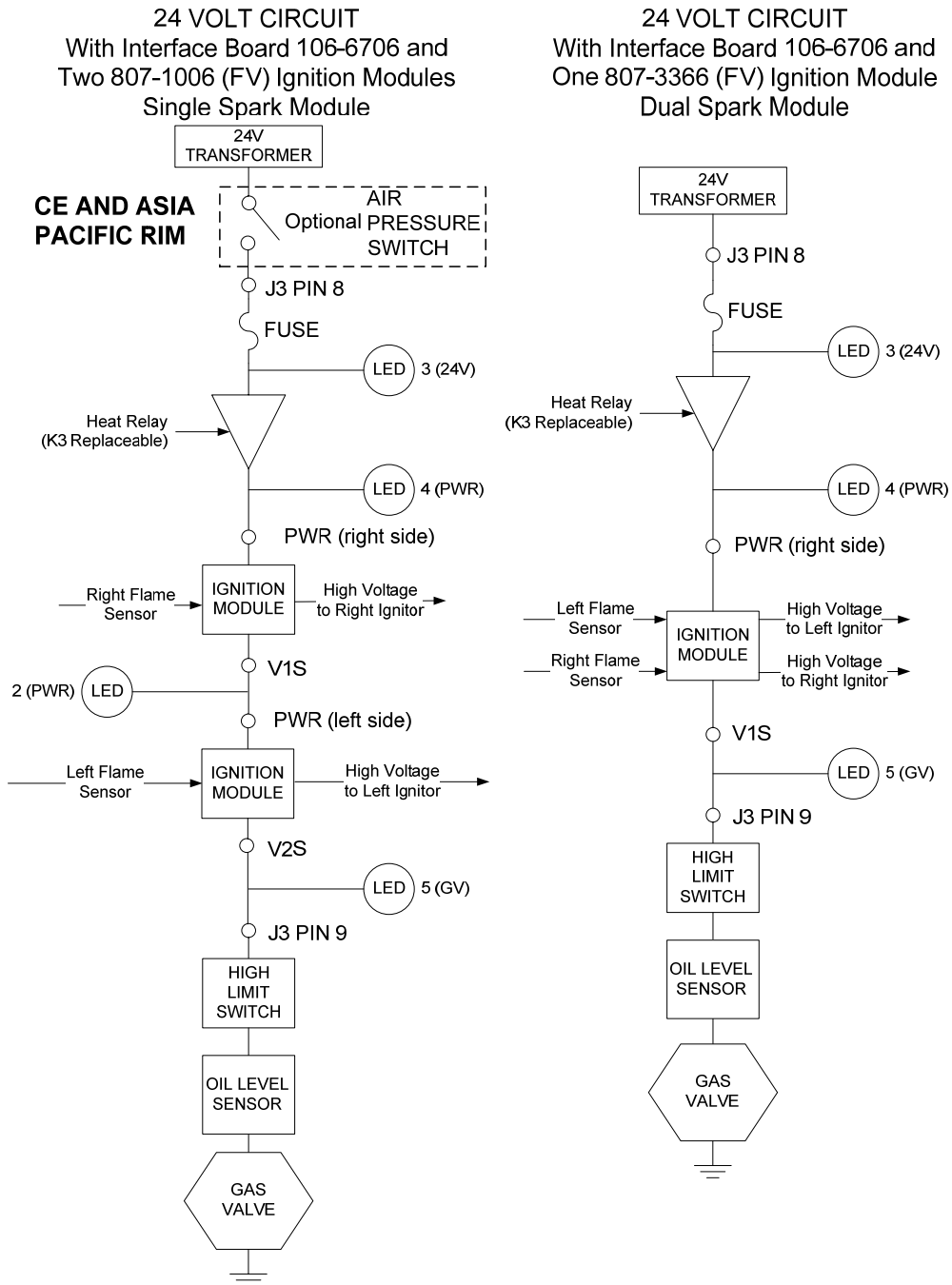

**24 VOLT CIRCUIT**  
 With Interface Board 106-6706 and  
 Two 807-3365 (DV) Ignition Modules

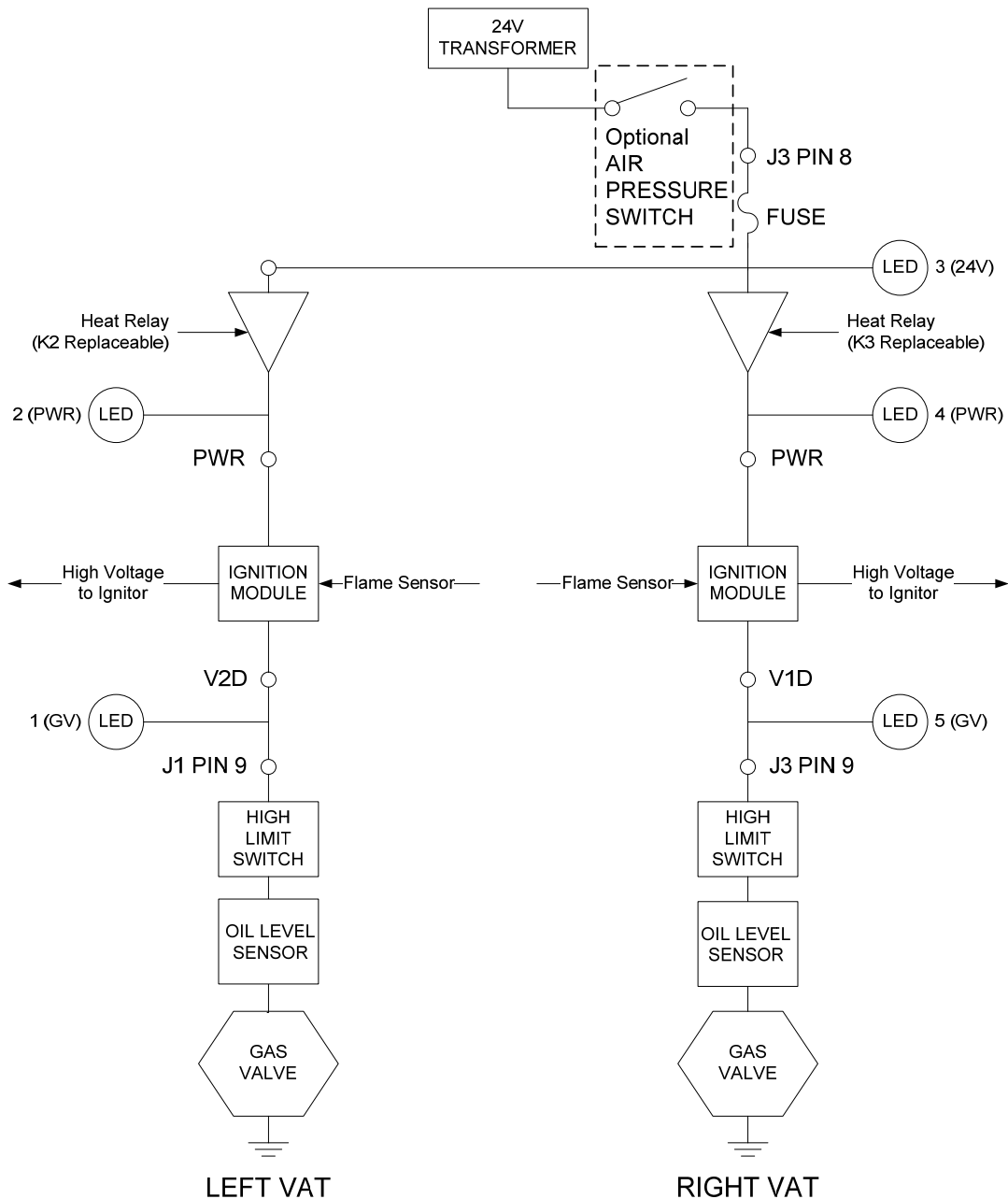

**1.11.2 Troubleshooting the Gas Valve**

Prior to checking for problems associated with the gas valve, ensure that the unit is calling for heat. Also, for non-CE units, verify that the gas valve is in the ON position.

The following processes will assist you in troubleshooting the gas valve and ruling it out as a probable cause:

- If 24 VAC is not present across gas valve main coil, the probable cause is the 24 VAC circuit. Refer to the 24 VAC circuit troubleshooting guide.
- If 24 VAC is present across gas valve main coil, check the incoming gas pressure and compare to the tables on page 2-4 of the Installation and Operation manual.

1. If incoming gas pressure *is not* correct, the probable cause is a problem with the gas supply to fryer.
2. If incoming gas pressure *is* correct, check the burner manifold gas pressure and compare it to the tables on page 2-7 of the Installation and Operation manual.
  - a. If burner manifold gas pressure *is not* correct, the probable cause is an improperly adjusted or failed gas valve. Adjust the valve by following the procedure “Check Burner Manifold Pressure” in Section 1.4 of this manual. If the valve cannot be adjusted, replace it.
  - b. If outgoing gas pressure *is* correct, the gas valve is okay.

### 1.11.3 Troubleshooting the Temperature Probe

**⚠ CAUTION**

**Disconnect the M3000 computer before testing temperature probe resistances to avoid invalid readings**

Prior to checking for problems associated with the temperature probe, inspect the probe body for damage while it is still in the frypot. Remove and replace the probe if it is bent, dented, or cracked. Also, inspect leads for fraying, burning, breaks, and/or kinks. If found, replace the probe.

The following processes will assist you in troubleshooting the gas valve and ruling it out as a probable cause:

*Before testing the probe, determine the temperature the cooking oil using another thermometer or pyrometer placed at the tip of the questionable probe.*

- If resistance through J3 pins 2 and 6 (J1 pins 2 and 6 for left side of dual unit) **is not** approximately equal to that given in the Probe Resistance Chart for the corresponding temperature, the probe has failed and must be replaced.
- If resistance through J3 pins 2 and 6 (J1 pins 2 and 6 for left side of dual unit) **is** approximately equal to that given in the Probe Resistance Chart for the corresponding temperature, measure the resistance through each of the previously tested pins to ground.
  1. If resistance *is not* 5 mega-Ohms or greater in each pin, the probe has failed and must be replaced.
  2. If resistance *is* 5 mega-Ohms or greater in each pin, the probe is okay.

### 1.11.4 Replacing the Transformer or Filter, Hood or Reset Switch Relay

Disconnect the fryer from the electrical power supply. Remove the cover from the transformer box in the rear of the fryer to expose the interior of the transformer box (see photo below). Replace the transformer or filter relay marking the wires to ease reassembly. Once replaced, reconnect the power. When replacing a filter relay in the transformer, ensure the 24VDC relay (8074482) is used.

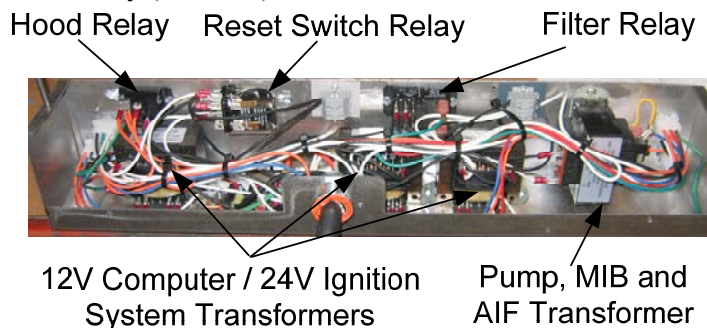

## 1.12 Probe Resistance Chart

| <h3 style="text-align: center;">Probe Resistance Chart</h3> <p style="text-align: center;"><i>For use with LOV™ Series fryers manufactured with Minco Thermistor probes only.</i></p> |      |    |     |      |    |     |      |     |     |      |     |     |      |     |  |  |  |
|---|------|----|-----|------|----|-----|------|-----|-----|------|-----|-----|------|-----|--|--|--|
| F   | OHMS | C  | F   | OHMS | C  | F   | OHMS | C   | F   | OHMS | C   | F   | OHMS | C   |  |  |  |
| 60  | 1059 | 16 | 130 | 1204 | 54 | 200 | 1350 | 93  | 270 | 1493 | 132 | 340 | 1634 | 171 |  |  |  |
| 65  | 1070 | 18 | 135 | 1216 | 57 | 205 | 1361 | 96  | 275 | 1503 | 135 | 345 | 1644 | 174 |  |  |  |
| 70  | 1080 | 21 | 140 | 1226 | 60 | 210 | 1371 | 99  | 280 | 1514 | 138 | 350 | 1654 | 177 |  |  |  |
| 75  | 1091 | 24 | 145 | 1237 | 63 | 215 | 1381 | 102 | 285 | 1524 | 141 | 355 | 1664 | 179 |  |  |  |
| 80  | 1101 | 27 | 150 | 1247 | 66 | 220 | 1391 | 104 | 290 | 1534 | 143 | 360 | 1674 | 182 |  |  |  |
| 85  | 1112 | 29 | 155 | 1258 | 68 | 225 | 1402 | 107 | 295 | 1544 | 146 | 365 | 1684 | 185 |  |  |  |
| 90  | 1122 | 32 | 160 | 1268 | 71 | 230 | 1412 | 110 | 300 | 1554 | 149 | 370 | 1694 | 188 |  |  |  |
| 95  | 1133 | 35 | 165 | 1278 | 74 | 235 | 1422 | 113 | 305 | 1564 | 152 | 375 | 1704 | 191 |  |  |  |
| 100   | 1143 | 38 | 170 | 1289 | 77 | 240 | 1432 | 116 | 310 | 1574 | 154 | 380 | 1714 | 193 |  |  |  |
| 105   | 1154 | 41 | 175 | 1299 | 79 | 245 | 1442 | 118 | 315 | 1584 | 157 | 385 | 1724 | 196 |  |  |  |
| 110   | 1164 | 43 | 180 | 1309 | 82 | 250 | 1453 | 121 | 320 | 1594 | 160 | 390 | 1734 | 199 |  |  |  |
| 115   | 1174 | 46 | 185 | 1320 | 85 | 255 | 1463 | 124 | 325 | 1604 | 163 | 395 | 1744 | 202 |  |  |  |
| 120   | 1185 | 49 | 190 | 1330 | 88 | 260 | 1473 | 127 | 330 | 1614 | 166 | 400 | 1754 | 204 |  |  |  |
| 125   | 1195 | 52 | 195 | 1340 | 91 | 265 | 1483 | 129 | 335 | 1624 | 168 | 405 | 1764 | 207 |  |  |  |

## 1.13 ATO (Automatic Top-off) Service Procedures

The automatic top-off system is activated when the oil level falls below a sensor in the front of the frypot. The signal is sent to the ATO board to engage the return actuator to the frypot and turn on the ATO pump. The pump draws oil from the JIB (Jug In Box) through the rear return manifold into the rear of the frypot. Once the oil level has satisfied the sensor, the pump turns off and the actuator closes.

The ATO board is located inside the box, behind the JIB (see Figure 1). The power for the ATO board is supplied from the transformer box. The power passes through the transformer inside the ATO box to the board.



Figure 1

### 1.13.1 ATO (Automatic Top-Off) Troubleshooting

| Problem   | Probable Causes   | Corrective Action  |
|---|---|--|
| <b>Fryer tops off cold.</b>                             | Incorrect setpoint.   | Ensure setpoint is correct.  |
| <b>No power to ATO board</b>                            | A. J5 connection unplugged<br>B. Fuse blown.<br>C. Transformer malfunction                          | A. Check to ensure J5 on front of ATO board is fully locked into connector.<br>B. Ensure fuse located on right side of ATO box is not blown.<br>C. Check that proper voltage is present at transformer. See table in section 1.13.2. |
| <b>The yellow JIB low light won't illuminate.</b>       | A. Loose wire connection.<br>B. Power not present in the transformer box.<br>C. Failed transformer. | A. Ensure the yellow LED is securely attached to plug J6 on the ATO board.<br>B. Ensure power is present in the transformer box.<br>C. If power is present in transformer box, check the transformer for correct voltage.            |
| <b>One vat tops off but other vats fail to top off.</b> | A. Loose wire connection.<br>B. Actuator issue.   | A. Ensure all wiring harnesses are securely connected to ATO board and solenoids.<br>B. Check return actuator to ensure actuator is functional.  |

| Problem  | Probable Causes   | Corrective Action  |
|--|---|--|
| <b>Frypots won't top off.</b>                      | <ul style="list-style-type: none"> <li>A. Empty JIB.</li> <li>B. Probe temperature lower than setpoint.</li> <li>C. Oil is too cold.</li> <li>D. Bad Connection</li> <li>E. ATO board power loss</li> <li>F. Failed transformer/harness.</li> <li>G. ATO pump failed.</li> <li>H. Failed ATO board.</li> <li>I. ATO lines/pump plugged</li> </ul> | <ul style="list-style-type: none"> <li>A. Ensure JIB has oil.</li> <li>B. Check to see that fryer is heating. Fryer temperature must be at setpoint. Check probe resistance. If probe is bad, replace the probe.</li> <li>C. Ensure that the oil in the JIB is above 70°F (21°C).</li> <li>D. With the computer OFF, press TEMP button and ensure the ATO software version appears. If not, the connection between the AIF and the ATO board may be bad. Ensure the 6-pin CAN connectors are tight between AIF (J4 and J5) and ATO (J9 or J10) boards.</li> <li>E. Power to the ATO board has been cut off. Restore power to the board and clear any service required errors.</li> <li>F. Ensure transformer in ATO box is functioning properly. Check power from transformer to ATO board. Ensure all harnesses are plugged securely into place.</li> <li>G. Ensure pump is operational. Check voltage to pump. Replace the pump if defective.</li> <li>H. Check for proper voltages using the pin position chart found on page 1-29. If ATO found defective, replace ATO board.</li> <li>I. Clear the lines/pump.</li> </ul> |
| <b>Incorrect vat tops off.</b>                     | <ul style="list-style-type: none"> <li>A. Wired incorrectly.</li> <li>B. Flexlines connected to wrong vat.</li> </ul>   | <ul style="list-style-type: none"> <li>A. Check wiring.</li> <li>B. Switch flexlines to correct vat.</li> </ul>  |
| <b>One vat doesn't top off.</b>                    | <ul style="list-style-type: none"> <li>A. Filter error exists.</li> <li>B. Actuator, pump, loose connection, RTD or ATO issue.</li> </ul>   | <ul style="list-style-type: none"> <li>A. Clear filter error properly. When change filter pad YES/NO is displayed, do NOT press any button until the pan has been removed for at least thirty seconds. After thirty seconds the computer returns to OFF or last display.</li> <li>B. Check actuator, ATO pump, ATO board, wire connections and RTD.</li> </ul>   |
| <b>M3000 displays SERVICE REQUIRED – ATO BOARD</b> | <ul style="list-style-type: none"> <li>A. Loose or bad fuse</li> <li>B. Bad Connection</li> <li>C. ATO Board power loss</li> </ul>  | <ul style="list-style-type: none"> <li>A. Ensure fuse on right side of ATO box is secure and good.</li> <li>B. With the computer OFF, press TEMP button and ensure the ATO software version appears. If not, the connection between the AIF and the ATO board may be bad. Ensure the 6-pin CAN connectors are tight between AIF (J4 and J5) and ATO (J9 or J10) boards.</li> <li>C. Power to the ATO board has been cut off. Ensure there is correct voltage to the ATO transformer. Restore power to the board and clear any service required errors.</li> </ul>  |

### 1.13.2 ATO (Automatic Top-Off) Board Pin Positions and Harnesses

| Connector                                 | From/To   | Harness #  | Pin # | Function          | Voltage | Wire Color |
|---|---|--|-------|-------------------|---------|------------|
| J8  | RTI Add Solenoid  | 8074671  | 1     | 24VAC Ret         | 24VAC   | Black      |
|   |   |  | 2     |                   |         |            |
|   |   |  | 3     |                   |         |            |
|   | ATO Pump Relay  |  | 4     | 24VAC Ret         | 24VAC   | Black      |
|   |   |  | 5     |                   |         |            |
|   |   |  | 6     |                   |         |            |
|   |   |  | 7     |                   |         |            |
|   | JIB Reset Switch  |  | 8     | JIB Low Reset     | 16VDC   | Black      |
|   | RTI Add Solenoid  |  | 9     | 24VAC             | 24VAC   | Red        |
|   |   |  | 10    |                   |         |            |
|   |   |  | 11    |                   |         |            |
|   | ATO Pump Relay  |  | 12    | 24VAC             | 24VAC   | Red        |
|   |   |  | 13    |                   |         |            |
|   |   |  | 14    |                   |         |            |
|   | JIB Reset Switch  |  | 15    |                   |         |            |
|   |   |  | 16    | Ground            | 16VDC   | Red        |
| J4 (Rear) /<br>J5 (Front)                 | Transformer   | 8074553  | 1     | 24VAC Ret         | 24VAC   | Orange     |
|   |   |  | 2     | 24VAC             |         | Blue       |
|   |   |  | 3     |                   |         |            |
|   |   |  | 4     |                   |         |            |
|   | ATO 4 & 5 Battery Jumper  | 8074657  | 5     | 12VAC Ret         | 12VAC   | Red        |
|   |   |  | 6     | 12VAC             |         | Brown      |
|   |   |  | 7     | Jumper            | Ohm     | Black      |
|   |   |  | 8     | Jumper            |         | Black      |
| J1 - Vat #1<br>J2 - Vat #2<br>J3 - Vat #3 | ATO RTD   | 8074655 - Vat #1<br>8074654 - Vat #2<br>8074655- Vat #3  | 1     | DV - Probe Ground | Ohm     | White      |
|   |   |  | 2     | DV - Probe        |         | Red        |
|   |   |  | 3     | FV - Probe Ground |         | White      |
|   |   |  | 4     | FV - Probe        |         | Red        |
| J6  | Orange LED  | 8074555  | 1     | 16VDC             | 16VDC   | Black      |
|   |   |  | 2     | 16VDC Ret         |         | Red        |
| J7  |   |  | 1     |                   |         |            |
|   |   |  | 2     |                   |         |            |
|   |   |  | 3     | Ground            |         |            |
|   |   |  | 4     | RB7/DATA          |         |            |
|   |   |  | 5     | RB6/CLOCK         |         |            |
| J10                                       | Network Resistor<br>(pins 2 & 3) or to next<br>ATO Board (4 & 5 vat<br>units) | 8074552<br>(Network<br>resistor),<br>8074546 to next<br>ATO board or<br>8074547 to LON<br>board. | 1     | Ground            |         | Black      |
|   |   |  | 2     | CAN Lo            |         | Red        |
|   |   |  | 3     | CAN Hi            |         | White      |
|   |   |  | 4     | 5VDC+             | 5VDC    | Black      |
|   |   |  | 5     | 24VDC             | 24VDC   | Red        |
|   |   |  | 6     | Ground            |         | White      |
| J9  | AIF J5  | 8074546  | 1     | Ground            |         | Black      |
|   |   |  | 2     | CAN Lo            |         | Red        |
|   |   |  | 3     | CAN Hi            |         | White      |
|   |   |  | 4     | 5VDC+             | 5VDC    | Black      |
|   |   |  | 5     | 24VDC             | 24VDC   | Red        |
|   |   |  | 6     | Ground            |         | White      |

### 1.13.3 Replacing the ATO Board or Transformer

Disconnect the fryer from the electrical power supply. Locate the ATO box (see Figure 1 on page 1-27), behind the JIB (Jug In Box). Remove the cover to expose the transformers, relay and LON gateway (if installed) (see Figure 2). Mark and unplug any wires or harnesses. Once the LON gateway is removed the ATO board is visible (see Figure 3). Replace the defective component and reattach all wires or harnesses. Replace the cover. Once replaced, **CYCLE POWER TO ENTIRE FRYER SYSTEM.** See section 1.14.6 to reset control power. Check software version and if necessary update the software. If a software update is necessary, follow the instructions to update the software in section 1.18.



Figure 2



Figure 3

Press the TEMP button on one of the M3000 computers to verify software version of the ATO. If the version is not visible, the ATO may not be connected properly.

### 1.13.4 Replacing the ATO Pump or Solenoid

Disconnect the fryer from the electrical power supply. Locate the ATO pump (see Figure 4), behind the ATO box. Mark and unplug any wires or harnesses. Press up from the bottom on the quick disconnects to release the plumbing (see Figure 5). The plumbing can be pulled from the pump. Loosen the four nuts attaching the pump to the pump tray. Replace the defective component and reverse above steps. Once replaced, reconnect the power.



Figure 4



Figure 5

## 1.14 MIB (Manual Interface Board) Service Procedures

The MIB (Manual Interface Board) oversees and controls filtration. It receives and sends data over the CAN (Controller Area Network) to and from various sensors and computers. It activates the filtration cycle, controlling when actuators should open and close.

The MIB controller is located inside the left cabinet (see Figure 6). In normal operation a cover hides the MIB controls and only the LED display is visible. The cover is held in place with a T-25 torx screw. In normal operation, an “A” is displayed for automatic mode. The MIB control board is useful for diagnostic purposes. It allows manual operation of both the actuators and filter pump without using the M3000 computer.

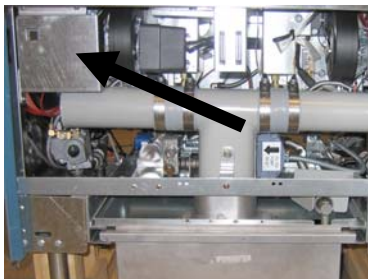

Figure 6: MIB controller cover.



Figure 7

## Buttons and LED's

**Manual** – This button is used to toggle between auto and manual filtration mode. A corresponding LED is lit when in Manual mode. When pressed, a message will be sent to all vats, indicating the mode has changed.

**The following buttons are inoperable in auto mode:**

**Select** - This button is used to scroll through available vats, choosing one to be manually filtered.

**Drain** – This button is used to open and close the drain on the vat indicated on the display. It's embedded LED indicates the following activity:

**Blink:** Actuator is moving or awaiting a response from the AIF board, or an error conditions exists.

**Constant Illumination:** Drain open.

**No Illumination:** Drain closed.

**Return** – This button is used to open and close the return valve on the vat indicated on the display. When pressed and held, it also turns on and off the pump. It's embedded LED indicates the following activity:

**Blink:** Actuator is moving or awaiting a response from the AIF board, or an error condition exists.

**Constant Illumination:** Return valve open.

**No Illumination:** Return valve closed.

The pump is turned off first before closing the return valve or the valve will open first before turning on the pump.

### 1.14.1 Manually Draining, Refilling or Filtering using the MIB board

Press the manual/auto switch to set to manual. The LED on the manual key will illuminate and a vat number is displayed (see Figure 8).

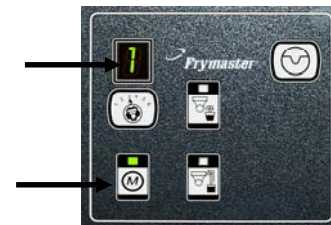

Figure 8

Press the vat selector switch to change vats (see Figure 9).



Figure 9

Pressing the drain or pressing the return switch illuminates and activates the drain or return valve for the vat indicated. Pressing and holding the return switch while the return is open activates the filter motor and pump (see Figure 10).

Pressing the manual/auto switch will return to automatic mode.



Figure 10

## 1.14.2 MIB (Manual Interface Board) Troubleshooting

| Problem   | Probable Causes  | Corrective Action  |
|---|--|--|
| <p><b>Auto filtration won't start.</b></p>  | <p>A. Filter pan out of position.<br/>           B. Oil level too low.<br/>           C. Ensure MIB board is not in manual mode.<br/>           D. Ensure MIB cover is not damaged and pressing against buttons.<br/>           E. Filter relay has failed.<br/>           F. AIF disable is set to YES, blue light doesn't light.<br/>           G. Filter motor thermal switch is tripped.<br/>           H. AIF clock enabled</p> | <p>A. Ensure filter pan is fully inserted into fryer. If the MIB board displays a “<b>P</b>” the pan is not fully engaged into the pan switch.<br/>           B. Ensure the oil level is above the top oil level sensor.<br/>           C. Ensure MIB board is in “<b>A</b>” automatic mode.<br/>           D. Remove and replace cover and see if filtration will start.<br/>           E. Replace filter relay with part number 807-4482 24VDC relay.<br/>           F. Set AIF disable in Level 1 to NO.<br/>           G. Press filter motor thermal switch.<br/>           H. Ensure AIF clock is set to disabled.</p>  |
| <p><b>MIB display shows something other than an “<b>A</b>” or vat number.</b></p> | <p>An error has occurred and displayed character indicates error.</p>  | <p>See MIB display characters on page 1-33 for explanation.</p>  |
| <p><b>No power present at the MIB board</b></p>                                   | <p>Transformer has failed in left component box.</p>   | <p>Check output on the left transformer in left component box; should read 24VAC. If not replace transformer.</p>  |
| <p><b>MIB will not clear error.</b></p>   | <p>Error remains in non-volatile memory.</p>   | <p>Press and hold reset button in top right corner of MIB board for five seconds. The drain, return and manual/auto LEDs will illuminate and the MIB will reset and clear any remaining errors from memory. Allow 60 seconds to reset. If an error still exists, then another issue exists.</p>  |
| <p><b>MIB indicates incorrect number of vats.</b></p>                             | <p>A. Network is not terminated correctly.<br/>           B. Wiring harnesses are loose or damaged.<br/>           C. An AIF board issue.<br/>           D. Locator pin issue.</p>   | <p>A. Ensure the CAN bus system is terminated at <b>BOTH ENDS</b> (on the M3000 connector J6 and on the ATO board connector J9) with a resistor equipped 6-pin connector.<br/>           B. Unplug and reseat all wiring harnesses in CAN system. Resistance between pins 2 and 3 on the CAN network connectors should be 120 ohms.<br/>           C. Check software version numbers on all M3000 computers and ensure all display an AIF version. If an AIF version is missing, the AIF board may be missing power or bad. Check pins 5 and on J4 and J5 of the affected AIF board for proper voltage.<br/>           D. The locator pin in J2 of the AIF board is either loose or in the incorrect position. See the charts on page 1-39 of this manual for proper pin position.</p> |

| Problem  | Probable Causes                                    | Corrective Action   |
|--|--|---|
| <p><b>MIB board alternating “E” and “vat number and side”.</b></p> | <p>Network error on the CAN bus communication.</p> | <ul style="list-style-type: none"> <li>A. Ensure the CAN bus system is terminated at <b>BOTH ENDS</b> (on the M3000 connector J6 and on the ATO board connector J10) with a resistor equipped 6-pin connector.</li> <li>B. With the computer OFF, press TEMP button and ensure the AIF version appears. If not, the 24V to the AIF boards may be missing. Ensure all 6-pin CAN connectors are tight between the M3000 (J6 and J7), MIB (J1 and J2), AIF (J4 and J5) and ATO (J10) boards.</li> <li>C. With the computer OFF, press TEMP button and ensure the ATO version appears. If not, check the CAN wire harness between the AIF board J4 or J5 and the ATO board J9 or J10. The ATO fuse on the right side of the ATO box may be loose or blown; the 110V to the ATO transformer may be missing or bad. The J4/J5 connector may be loose.</li> <li>D. Check to see if MIB has 24V on pins 5 and 6 of J2. Check to see if 24V is present on pins 5 and 6 of wire harness plugging into J4 or J5 of the first AIF board. If 24V missing, check the pins. Replace the harness if necessary.</li> <li>E. Check continuity between each color wire on the CAN connectors into J7 on the far right computer and J10 on back of the ATO board (black to black, white to white, and red to red), and ensure there is no continuity between different color wires (black to red, red to white, and white to black).</li> <li>F. Ensure black computer locator wires are connected from ground to correct pin position (see drawing 8051725 page 1-59).</li> <li>G. Ensure all boards have the corner ground wire attached and tightened.</li> <li>H. The locator pin in J2 of the AIF board is either loose or in the incorrect position. See the charts on page 1-39 of this manual for proper pin position.</li> <li>I. Bad MIB and/or AIF board.</li> <li>J. Broken resistor lead. Unwrap the resistor leads and check ends.</li> </ul> |

### 1.14.3 MIB (Manual Interface Board) Pin Positions and Harnesses

| Connector | From/To                            | Harness #                                | Pin # | Function   | Voltage                         | Wire Color |  |
|-----------|------------------------------------|--|-------|--|---------------------------------|------------|--|
| J1        | M3000 J6                           | 8074546                                  | 1     | Ground   |                                 | Black      |  |
|           |                                    |  | 2     | CAN Lo   |                                 | Red        |  |
|           |                                    |  | 3     | CAN Hi   |                                 | White      |  |
|           |                                    |  | 4     |  |                                 |            |  |
|           |                                    |  | 5     |  |                                 |            |  |
|           |                                    |  | 6     |  |                                 |            |  |
| J2        | AIF J5                             | 8074850                                  | 1     | Ground   |                                 | Black      |  |
|           |                                    |  | 2     | CAN Lo   |                                 | Red        |  |
|           |                                    |  | 3     | CAN Hi   |                                 | White      |  |
|           |                                    |  | 4     | 5VDC+  | 5VDC                            | Black      |  |
|           |                                    |  | 5     | 24VDC  | 24VDC                           | Red        |  |
|           |                                    |  | 6     | Ground   |                                 | White      |  |
| J5        | Transformer                        | 8074780<br>RTI<br><br>8074562<br>NON-RTI | 1     | 24VAC  | 24VAC                           | Black      |  |
|           |                                    |  | 2     | 24VAC Ret  |                                 | White      |  |
|           | Filter Relay                       |  | 3     | Pump Motor   | 24VDC                           | Red        |  |
|           |                                    |  | 4     | Pump Motor   |                                 | Green      |  |
|           | Blue LED                           |  | 5     | Blue LED +   | 24VDC                           | Red        |  |
|           |                                    |  | 6     | Blue LED -   |                                 | Black      |  |
|           | RTI Open Switch                    |  | 7     | Open Switch +                                      |                                 | Black      |  |
|           | RTI Closed Switch                  |  | 8     | Closed Switch +                                    |                                 | Red        |  |
|           |                                    |  | 9     |  |                                 |            |  |
|           |                                    |  | 10    |  |                                 |            |  |
|           | Pan Switch                         |  | 11    | Pan Sw +   | 24VDC                           | Black      |  |
|           |                                    |  | 12    | Pan Sw -   |                                 | Red        |  |
|           |                                    |  | 13    |  |                                 |            |  |
|           |                                    |  | 14    |  |                                 |            |  |
|           | RTI Open Switch                    |  | 15    | Ground -   |                                 | White      |  |
|           | RTI Closed Switch                  |  | 16    | Ground -   |                                 | Green      |  |
| J6        | To RTI connection in rear of fryer | 8074760                                  | 1     | From RTI transformer                               | 24VAC                           | Black      |  |
|           |                                    |  | 2     | Common   |                                 | White      |  |
|           |                                    |  | 3     | To RTI "Add Pump" Relay                            | 24VAC                           | Green      |  |
|           |                                    |  | 4     |  |                                 |            |  |
|           |                                    |  | 5     |  |                                 |            |  |
|           |                                    |  | 6     |  |                                 |            |  |
|           |                                    |  | 7     |  |                                 |            |  |
|           |                                    |  | 8     | From RTI "Waste Tank Full Sensor" Test Pins 2 to 8 | 24VAC – Full<br>0VAC – Not Full | Red        |  |

### 1.14.4 MIB (Manual Interface Board) Display Characters

**A** – Auto Mode – Auto Filtration enabled.

**E** – Drain or return valve is not in desired state. The display will alternate between **E** and the corresponding vat number. Ensure the actuator is plugged in and an error does not exist.



– Three horizontal lines indicate the AIF temperature sensor did not detect that the vat was full during auto filtration.

**n** – Network Error - An “n” displays for 10 seconds if no communication is received from the cooking computer within ten seconds after a power on or MIB reset.

**P** – Pan Switch – Filter pan is improperly seated. Filtration is suspended.

**r** – Reset Switch - Reset the vat closes all of the valves on the vat. If displayed for some time, there is probably a problem with the board.

**1 – 5** – Numbers which correspond to the vats with either an “L” indicating the left side of a split vat or “r” indicating the right side of a split vat or a full vat. These numbers are displayed in manual mode.

### 1.14.5 Replacing the MIB Board

Disconnect the fryer from the electrical power supply. Remove the torx screw from the bottom of the MIB cover, exposing the MIB board (see Figure 11). Remove the two cabinet screws at the top (see Figure 12). Carefully hinge down the MIB board. Carefully remove the plugs on the rear of the board (see Figure 13). Replace with a new MIB board and reverse steps to reassemble. Once replaced, reconnect the power. Readdress the MIB board following the instructions in the next section. Once replaced, **CYCLE POWER TO ENTIRE FRYER SYSTEM**. See next section to reset control power. Check software version # and if necessary update the software. If a software update is necessary, follow the instructions to update the software in section 1.18 ensuring the MIB reset button is pressed and held for five seconds at the end of the update to update the MIB.

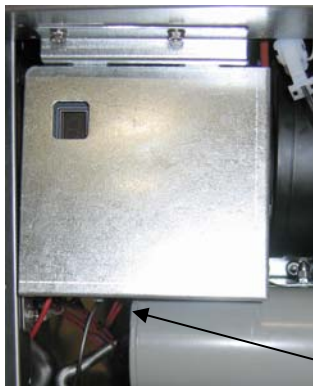

Figure 11

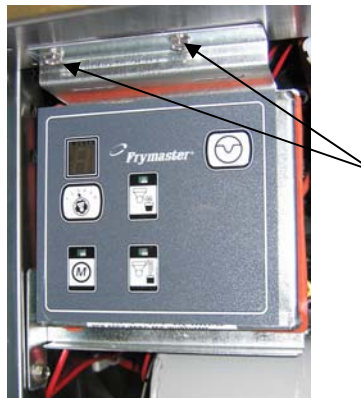

Figure 12

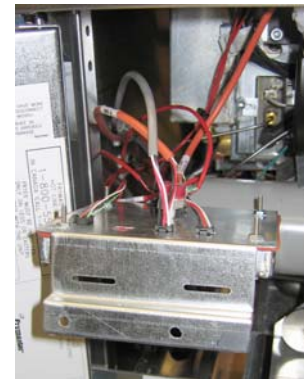

Figure 13

### 1.14.6 Control Power Reset Switch

The control power reset switch, is a momentary rocker switch located below the left control box (see Figures 14), that resets all power to all the computers and boards in the fryer. It is necessary to reset all power after replacing any computer or board. Press and hold the switch for at least ten seconds when resetting the control power to ensure power has sufficiently drained from boards.



Figure 14

## **1.15 RTI (Restaurant Technology Inc.)Service Issues**

### **1.15.1 RTI MIB Tests**

**RTI (Restaurant Technology Inc.) provides fresh and waste bulk oil service for McDonald's in the United States. The instructions in this manual for using a bulk oil system for filling and discarding oil are for an RTI system only. These instructions may NOT be applicable to other bulk oil systems.**

**The LOV™ fryer will ONLY operate with RTI systems that have the new RTI updated three-pole float switch. If the float switch is the older two-pole switch, call RTI. These float switches are polarity specific which may short to ground and damage an MIB board.**

#### **Normal measurements (MIB J6 8-pin connector with everything connected)**

##### **AC voltage measurements:**

Pin 1 to Pin 2 - 24 VAC.

Pin 2 to Pin 8 - 24 VAC when waste tank is full, 0 VAC when it is not full.

Pin 1 to Pin 3 - 24 VAC when RTI add switch and pump is on, 0 VAC when it is off.

Using the RTI test box, PN# 108-0716 allows a quick and easy way to check the 24VAC, the waste full switch and when the RTI pump is operating.

#### **Troubleshooting**

All return and drain valves should be closed and pump should be off while the MIB is resetting. If any of the valves or the pump is on during reset, the MIB board is bad or wires are shorted.

##### **RTI pump is not operating or JIB is not filling:**

See page 1-37 to ensure that no other function is taking priority over adding oil to jug.

1. Reset the power; wait 60 seconds and see if the valve opens.

With the JIB button pressed:

2. Voltage at MIB board from Pin 1 to Pin 2 should be 24 VAC; if not, check connections from RTI 24VAC transformer and check transformer.
3. Voltage at MIB board from Pin 1 to Pin 3 should be 24 VAC when filling JIB or vat; if not, the MIB board is bad or wires to pump relay are shorted or both.
4. Voltage at Add pump relay should be 24 VAC; if not, check wiring from MIB board. The relay is located on top of RTI system.
5. Check voltage at ATO board on J8. Pin 9 to Pin 1 should be 24 VAC with the orange button pressed.

##### **Waste full signal:**

Pin 2 to Pin 8 should be 24 VAC when full, 0 VAC when not full; if no voltage level change, the connection from RTI switch or MIB board is bad.

### 1.15.2 RTI LOV™ Wiring with RTI Switchbox

#### BULK OIL LOV WIRING

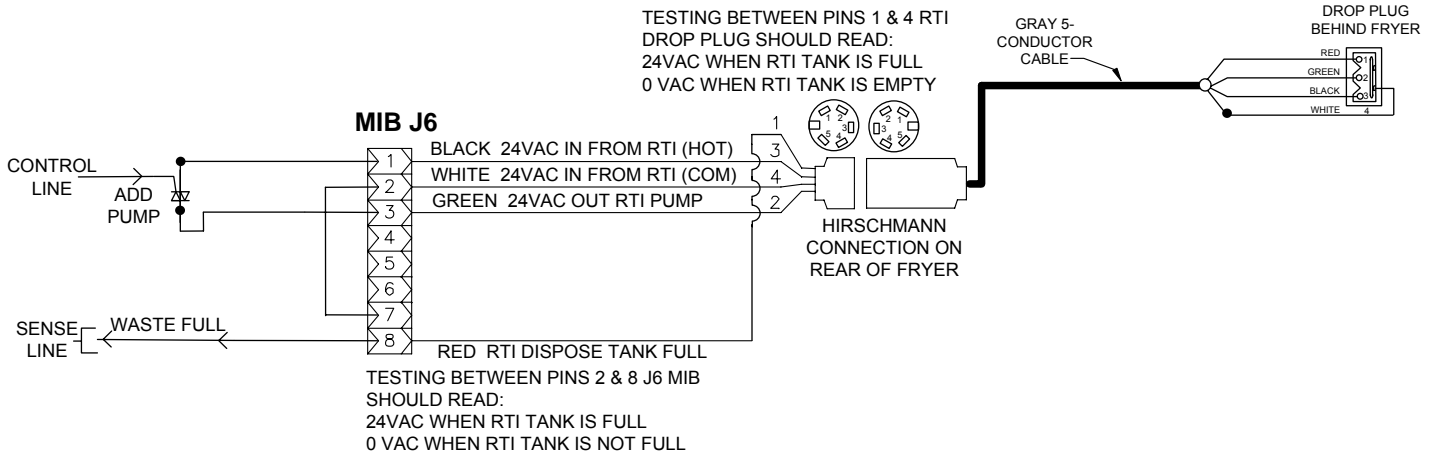

### 28.15.3 Frymaster LOV™ Fryer and RTI Bulk Oil System Plumbing Schematic

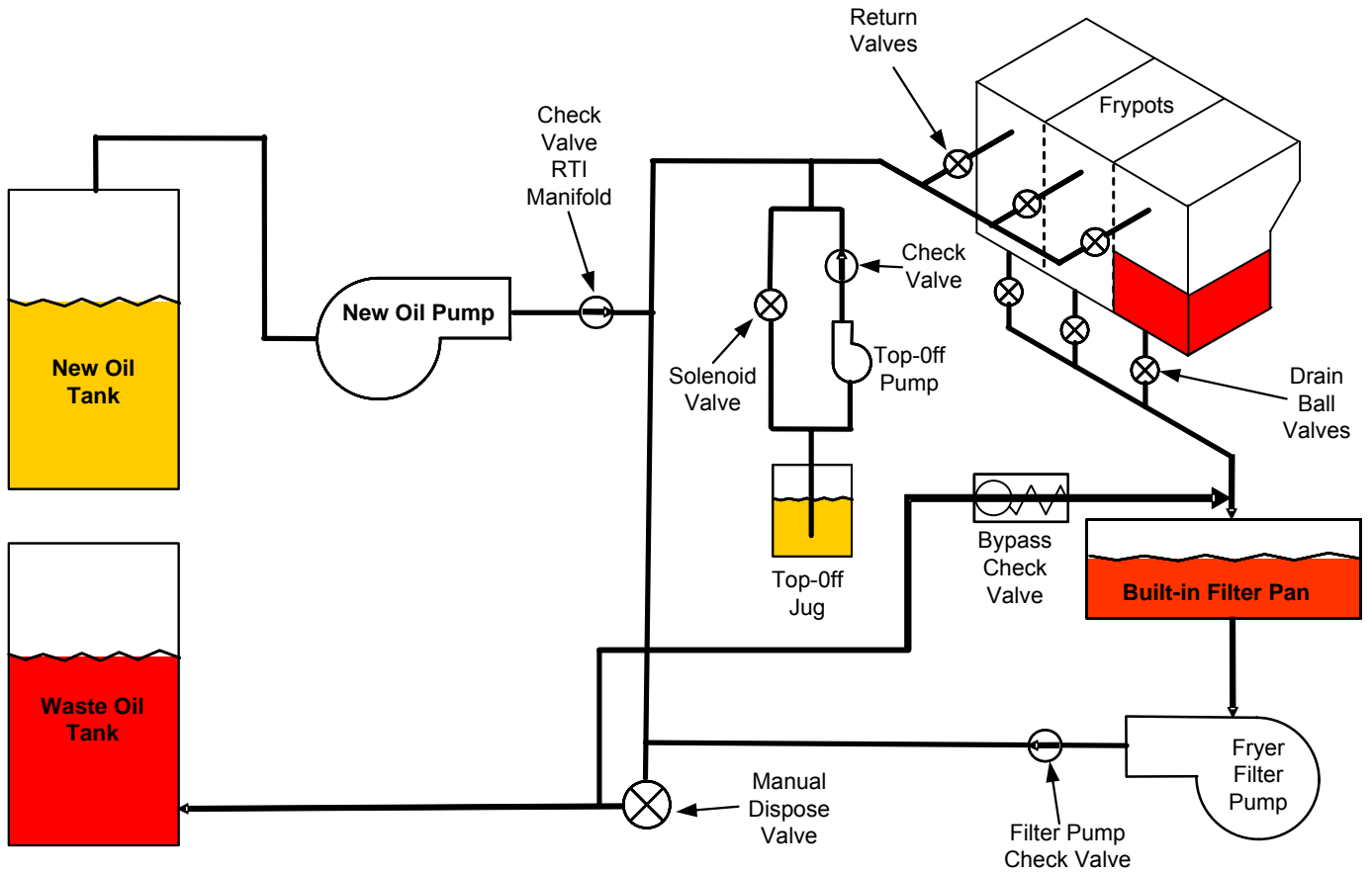

## 1.15.4 RTI LOV™ TEST QUICK REFERENCE

### DISPOSE TO WASTE, REFILL VAT FROM BULK:

1. Hold down “Filter” button until computer beeps twice.
2. Scroll down to “Dispose” using “Info” button then press “✓” button.
3. “Dispose? Yes/No” is displayed.\*
4. Press “✓” to dispose of oil in pot.
5. “Draining” is displayed.
6. “Vat Empty? Yes” is displayed.
7. Press “✓”.
8. “Cln Vat Complete? Yes” is displayed.
9. Press “✓”.
10. “Open Dispose Valve” is displayed. Open dispose valve.
11. “Disposing” is displayed for five minutes.
12. “Remove Pan” is displayed. Remove pan.
13. “Is Pan Empty? Yes No” is displayed.
14. Press “✓” if filter pan is empty. Select “✘” if pan still has oil in it.
15. “Close Dispose Valve” is displayed. Close dispose valve.
16. “Insert Pan” is displayed. Insert pan.
17. “Fill Vat From Bulk? Yes/No” is displayed.
18. Press “✓”.
19. “Press and Hold Yes to Fill” alternating with “Yes” is displayed.
20. Hold down “✓” to fill pot to desired level.
21. “Filling” is displayed while button is depressed.
22. “Continue Filling Yes/No” is displayed
23. Press “✓” to continue filling or “✘” to Exit program.

\*NOTE: If the waste tank is full, the computer displays “RTI Tank Full.” Call RTI.

### DISPOSE TO WASTE:

1. Hold down “Filter” button until computer beeps twice.
2. Scroll down to “dispose” using “Info” button and press “✓” button.
3. “Dispose? Yes/No is displayed.
4. Press “✓”.
5. “Draining” is displayed.
6. “Vat Empty? Yes is displayed.
7. Press “✓”
8. “Cln Vat Complete? Yes” is displayed.
9. Press “✓”.
10. “Open Dispose Valve” is displayed.
11. Open dispose valve by pulling completely forward to start disposal.
12. “Disposing” is displayed for four minutes.
13. “Remove Pan” is displayed.
14. Slide the filter pan slightly out of the fryer.
15. “Is Pan Empty? Yes/No” is displayed.
16. Press “✓” if the filter pan is empty. Select “✘” if pan still has oil in it.
17. “Close Dispose Valve” is displayed.
18. Close the dispose valve ensuring the handle is pushed completely towards the fryer.
19. “Insert Pan” is displayed.
20. “Fill Vat From Bulk? Yes/No” is displayed.
21. Press “✘” if you wish to leave pot empty and exit.

### FILL VAT FROM BULK:

1. Hold down “filter” button until computer beeps twice.
2. Scroll down to “Fill Vat from Bulk” using the Info button.
3. Press “✓”.
4. “Fill Vat from Bulk? Yes/No” is displayed.
5. Press “✓”.

6. “Press and Hold Yes to Fill / Yes” is displayed.
7. Press and hold down “✓” to fill pot to desired level.
8. “Filling” is displayed during fill.
9. Release button to stop filling.
10. “Continue Filling? Yes/No” is displayed.
11. Press “✕” to exit.

#### **FILL JUG FROM BULK:\***

1. When “Orange” indicator light is on, the top-off jug is empty.
2. To refill jug press and hold the orange reset button above the jug until the jug is full.
3. Release the button to stop filling.

**\*NOTE: The jug may not fill if any of the following are in progress:**

If FILTER NOW? YES/NO, CONFIRM YES/NO, or SKIM VAT is displayed, the fill jug button is disabled until either a filter is complete or until no is chosen.

**The system also checks these conditions. The following must be met before jug fill is allowed.**

Solenoid closed

- Orange fill button pressed longer than 3 sec.
- Waste valve closed
- Filter Now? Yes/No, Confirm Yes/No, or Skim Vat cannot be displayed
- System power cycle (all boards – computers, MIB, AIF and ATO) after changing setup from JIB to Bulk (use momentary reset). Ensure reset is pressed and held for at least ten seconds.
- No filtration or other filter menu selection can be in process.

**Other factors that may not allow fill jug from bulk –**

- Defective solenoid
- Defective switch
- RTI pump issue
- RTI relay stuck

If using two fryer systems that are both attached to the RTI system, they may not be able to fill both units at the same time if they have an RTI unit with a single head. Some RTI units have dual heads which can fill simultaneously.

## 1.16 AIF (Automatic Intermittent Filtration) Service Procedures

The AIF (Automatic Intermittent Filtration) board controls the actuators that open and close the drain and return valve. The AIF boards are located inside a protective housing under each frypot (see Figure 15).

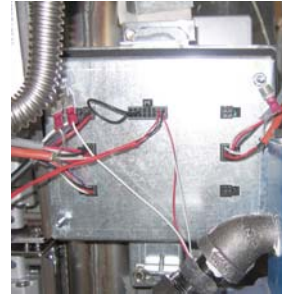

Figure 15

### 1.16.1 AIF (Automatic Intermittent Filtration) Troubleshooting

| Problem                                 | Probable Causes  | Corrective Action  |
|---|--|--|
| <b>Actuator doesn't function.</b>       | <ul style="list-style-type: none"> <li>A. No power to the AIF board.</li> <li>B. Actuator is unplugged.</li> <li>C. AIF board failure.</li> <li>D. Actuator readings are out of tolerance.</li> <li>E. Actuator is bad.</li> </ul> | <ul style="list-style-type: none"> <li>A. Check pins 5 and 6 of J2 at the MIB board. Should read 24VDC. Check voltage on pins 5 and 6 at the other end of harness and ensure 24VDC is present. Continue to check pins 5 and 6 for 24VDC on plugs J4 and J5 on the AIF boards.</li> <li>B. Ensure the actuator is plugged into the proper connection (J1 for FV return, J3 for DV return and J6 for FV drain and J7 for DV drain).</li> <li>C. Check power on the connector of the problem actuator while trying to manually open or close an actuator. Pins 1 (Black) and 4 (White) should read +24VDC when the actuator is opening. Pins 2 (Red) and 4 (White) should measure -24VDC when the actuator is closing). If either voltage is missing, the AIF board is likely bad. Test the actuator by plugging into another connector. If the actuator operates, replace the board.</li> <li>D. Check resistance of the potentiometer between pin 3 (purple wire) and pin 4 (gray/white wire). Closed should read 0-560Ω. Open should read 3.8K Ω – 6.6K Ω.</li> <li>E. If proper voltages are present at the connector and actuator doesn't operate reset power to the fryer. If it still doesn't operate replace the actuator.</li> </ul> |
| <b>Actuator functions on wrong vat.</b> | <ul style="list-style-type: none"> <li>A. Actuator plugged into wrong connector.</li> <li>B. Locator pin is in wrong position.</li> </ul>  | <ul style="list-style-type: none"> <li>A. Ensure the actuator is plugged into correct connection (J1 for FV return, J3 for DV return and J6 for FV drain and J7 for DV drain).</li> <li>B. Ensure the locator pin is in proper position in plug J2. See table B on page 1-59.</li> </ul>   |

### 1.16.2 AIF (Auto Intermittent Filtration) Actuator Board Pin Positions and Harnesses

| Connector | From/To                | Harness PN   | Pin # | Function         | Voltage | Wire Color |  |
|-----------|------------------------|--|-------|------------------|---------|------------|--|
| J1        | FV Return              | N/A  | 1     | Ret + (Open)     | 24VDC   | Black      |  |
|           |                        |  | 2     | Ret – (Closed)   | 24VDC   | Red        |  |
|           |                        |  | 3     | Ret Position     |         | Purple     |  |
|           |                        |  | 4     | Ground           |         | White      |  |
| J2        | FV AIF RTD             |  | 1     | Ground           |         | White      |  |
|           | DV AIF RTD             |  | 2     | FV - Temp        |         | Red        |  |
|           |                        |  | 3     | Ground           |         | White      |  |
|           |                        |  | 4     | DV - Temp        |         | Red        |  |
|           |                        |  | 5     |                  |         |            |  |
|           |                        |  | 6     |                  |         |            |  |
|           |                        |  | 7     |                  |         |            |  |
|           | 8                      |  |       |                  |         |            |  |
|           | Oil Level Sensor (Gas) |  | 9     | DV – OLS (Gas)   |         | Black      |  |
|           |                        |  | 10    | FV – OLS (Gas)   |         | Red        |  |
|           | Locator Pin            |  | 11    | Locator Vat #5   |         | Black      |  |
|           |                        |  | 12    | Locator Vat #4   |         |            |  |
|           |                        |  | 13    | Locator Vat #3   |         |            |  |
|           |                        |  | 14    | Locator Vat #2   |         |            |  |
|           |                        |  | 15    | Locator Vat #1   |         |            |  |
|           | Locator                |  | 16    | Locator Signal   |         | Black      |  |
| J3        | DV Return              | N/A  | 1     | Ret + (Open)     | 24VDC   | Black      |  |
|           |                        |  | 2     | Ret – (Closed)   | 24VDC   | Red        |  |
|           |                        |  | 3     | Ret Position     |         | Purple     |  |
|           |                        |  | 4     | Ground           |         | White      |  |
| J4        | MIB J2 or AIF J5       | 8074547<br>AIF Board<br>Communication<br>and Power | 1     | Ground           |         | Black      |  |
|           |                        |  | 2     | CAN Lo           |         | Red        |  |
|           |                        |  | 3     | CAN Hi           |         | White      |  |
|           |                        |  | 4     | 5VDC+            | 5VDC    | Black      |  |
|           |                        |  | 5     | 24VDC            | 24VDC   | Red        |  |
|           |                        |  | 6     | Ground           |         | White      |  |
| J5        | AIF J4 or ATO J10      | 8074547<br>AIF Board<br>Communication<br>and Power | 1     | Ground           |         | Black      |  |
|           |                        |  | 2     | CAN Lo           |         | Red        |  |
|           |                        |  | 3     | CAN Hi           |         | White      |  |
|           |                        |  | 4     | 5VDC+            | 5VDC    | Black      |  |
|           |                        |  | 5     | 24VDC            | 24VDC   | Red        |  |
|           |                        |  | 6     | Ground           |         | White      |  |
| J6        | FV Drain               | N/A  | 1     | Drain + (Open)   | 24VDC   | Black      |  |
|           |                        |  | 2     | Drain – (Closed) | 24VDC   | Red        |  |
|           |                        |  | 3     | Drain Position   |         | Purple     |  |
|           |                        |  | 4     | Ground           |         | White      |  |
| J7        | DV Drain               | N/A  | 1     | Drain + (Open)   | 24VDC   | Black      |  |
|           |                        |  | 2     | Drain – (Closed) | 24VDC   | Red        |  |
|           |                        |  | 3     | Drain Position   |         | Purple     |  |
|           |                        |  | 4     | Ground           |         | White      |  |

### 1.16.3 Replacing an AIF (Automatic Intermittent Filtration) Board

Disconnect the fryer from the electrical power supply. Locate the AIF board to be replaced under a frypot. Mark and unplug the harnesses. The AIF board assembly is held in place with one screw (see Figure 16). Remove the screw and the assembly drops down (see Figure 17) and the tab slides out of the bracket attached to the frypot (see Figure 18). Reverse steps to reassemble, ensuring that the new AIF assembly slides into the slot in the bracket. Once complete, **CYCLE POWER TO ENTIRE FRYER SYSTEM**. See section 1.14.6 to reset control power. Check software version # and if necessary update the software. If a software update is necessary, follow the instructions to update the software in section 1.18.

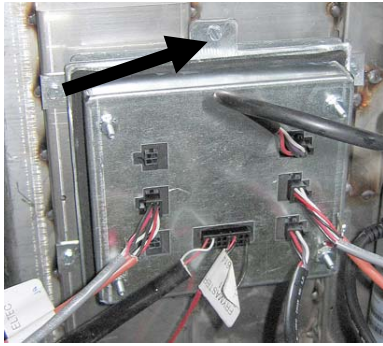

Figure 16

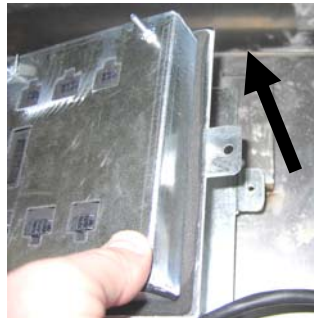

Figure 17

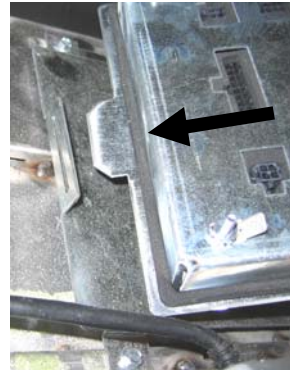

Figure 18

### 1.16.4 Replacing a Linear Actuator

Disconnect the fryer from the electrical power supply. Locate the actuator to be replaced under a frypot and mark and unplug the actuator. The actuators are held in place by two clevis pins which are held in by “J” clips (see Figure 19). Twist and remove both “J” clips and clevis pins (see Figure 20). It may be necessary to remove the AIF board to access the pins. Remove the actuator and attach the new actuator with only the rear clevis pin and “J” clip. Align the alignment holes and insert the clevis pin into both holes (see Figure 21). Rotate the actuator shaft until the holes of the shaft and valve plate align (see Figure 22). Remove the pin from the alignment hole and insert into the actuator shaft and valve handle (see Figure 23). Insert the “J” pin to secure (see Figure 24).

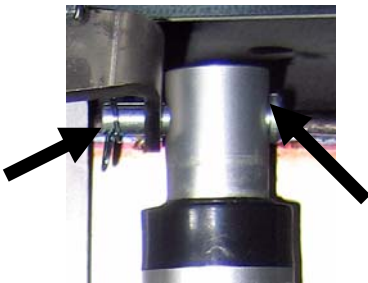

Figure 19



Figure 20



Figure 21

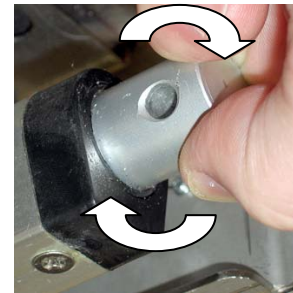

Figure 22



Figure 23



Figure 24

### 1.16.5 Replacing a Rotary Actuator

Disconnect the fryer from the electrical power supply. Locate the actuator to be replaced and mark and unplug the actuator. The actuators are held in place by two allen screws. Loosen the allen screws. It may be necessary to remove a gas line to the burner when removing a drain actuator. Remove the actuator from the valve stem. Align the actuator with the valve stem and attach the new actuator. Tighten the two allen screws. Reconnect power and test the actuator.

**NOTE:** Rotary actuators have two different part numbers, which are mirror images of each other that correspond to their mounting position.

### 1.16.6 Oil Level Sensor

The oil level sensor is a device that is used to prevent dry firing of the frypot (see Figure 25). The sensor looks similar to a high limit. The sensor is energized when the computer is powered on with a soft on. The sensor heats up and detects the oil around it. During filtration when the oil is drained, it senses the difference between the oil and air. It is controlled with a board located next to the interface board (see Figure 26) and a separate egg shaped plastic device (see Figure 27) that contains additional electronics. Use care when working with the sensor as temperatures may reach as high as 500°F (260°C).



Figure 25

If oil is surrounding the heater, the oil will prevent the heater from ever reaching its setpoint. Once oil is removed during filtration the heater reaches setpoint and cycles a thermostat every four seconds. Since the cycle is only four seconds, the seven second delay is not made and the gas valve won't open.

The 120VAC (220-240VAC on Intl. units) is on T2 in the control box traveling in on pin 11 of J3 and out pin 7 on J1 (DV) or pin 7 on J3 (FV).



Figure 26



Figure 27

#### 1.16.6.1 Oil Level Sensor Troubleshooting

##### Typical Sensor Related Failures

- Low temp but no call for heat (heat light)
- Stuck in melt cycle with no call for heat
- Filter error (IS VAT FULL?) with oil in the filter pan (no oil in the vat)

If the computer doesn't exit melt cycle or continues to display low temp and does not heat, and gas supply, gas valve, etc. have been checked and no heat lamp illuminates because no call for heat is initiated, then follow these steps:

- Check (see diagram next page)
  - Power to oil sensor (from oil level sensor (previous basket lift) relay on interface board K1 (DV) or K4 (FV)). Check pin 7 on J1 (DV) or pin 7 on J3 (FV) for 120VAC (220-240VAC on Intl. units).
  - Power to heater/relay coil on relay board. Check voltage to the coil between pins 8 and 1 to ensure that 120VAC (220-240VAC on Intl. units) is present with oil in the vat. If the vat is empty, the power will

cycle 4 seconds on, 4 seconds off.

- Check between pin 3 and 2 on the relay board reads 5VDC for air and 0VDC for oil. A common message for a shorted harness or issue is “IS DRAIN CLEAR?” with oil in the filter pan.
- Check ground on pin 2 on relay board to stud for a secure ground.
- Check AIF communication harness. Interrupted communication will prevent the fryer from heating.
- If the oil level sensor is cycling 4 sec. on/off and oil is surrounding the sensor, the sensor may have a carbon build up that is self insulating the sensor. Use a no scratch pad to remove carbon build up.

### 1.16.6.2 Oil Level Sensor Diagram

**NOTE:** See page 1-61 for alternate time delay relays.

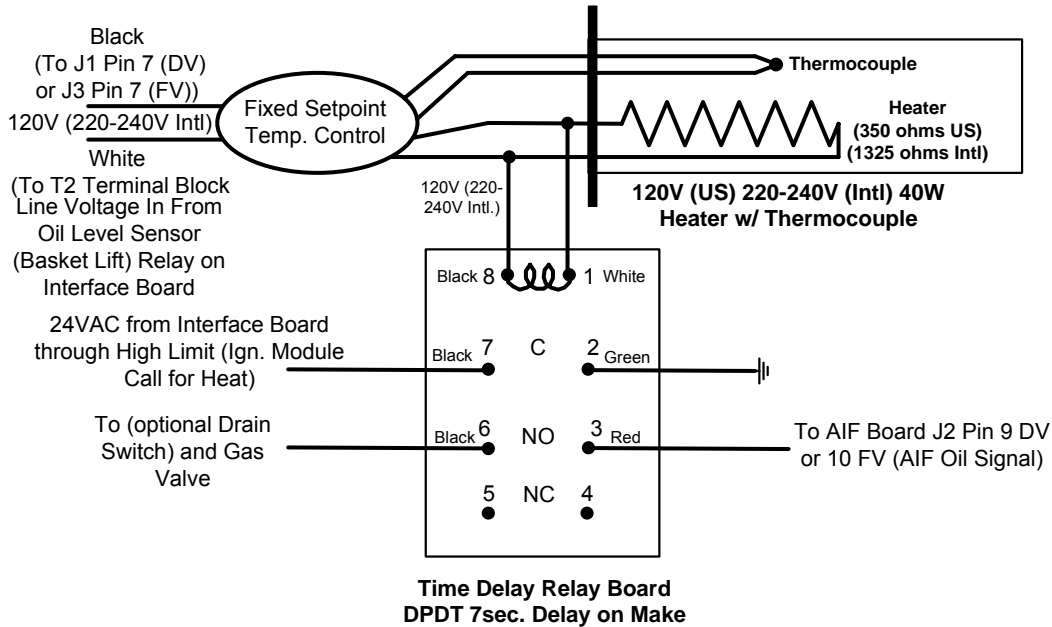

## 1.17 M3000 Computer Service Procedures

### 1.17.1 M3000 Computer Troubleshooting

| Problem                 | Probable Causes   | Corrective Action   |
|-------------------------|---|---|
| No Display on Computer. | <ul style="list-style-type: none"> <li>A. Computer not turned on.</li> <li>B. No power to the fryer.</li> <li>C. Computer has failed.</li> <li>D. Damaged computer wiring harness.</li> <li>E. Power supply component or interface board has failed.</li> </ul> | <ul style="list-style-type: none"> <li>A. Press the ON/OFF switch to turn the computer on.</li> <li>B. If the computer cord is not plugged in, the computer will not activate. Verify computer power cord is plugged in and that circuit breaker is not tripped.</li> <li>C. Swap the computer with a computer known to be good. If computer functions, replace the computer.</li> <li>D. Swap with a harness known to be good. If computer functions, replace the harness.</li> <li>E. If any component in the power supply system (including the transformer and interface board) fail, power will not be supplied to the computer and it will not function.</li> </ul> |
| Computer locks up.      | Computer error.   | Remove and restore power to the computer.   |

| <b>Problem</b>  | <b>Probable Causes</b>   | <b>Corrective Action</b>   |
|---|--|--|
| <b>M3000 displays RECOVERY FAULT.</b>                                       | Recovery time exceeded maximum time limit for two or more cycles.  | Silence the alarm by pressing the ✓ button. Check that fryer is heating properly. Maximum recovery for gas is 2:25. If this error continues to appear call your ASA.   |
| <b>M3000 displays ENERGY MISCONFIGURED</b>                                  | Wrong energy type selected in setup.   | Press 1234 to enter setup and set energy type for electric.  |
| <b>M3000 displays ERROR RM SDCRD</b>  | Defective SD Card  | Replace card with another card.  |
| <b>MAINT FILTER (Manual Filter) won't start.</b>                            | Temperature too low.   | Ensure fryer is at setpoint before starting <b>MAINT FILTER</b> .  |
| <b>M3000 displays FILTER BUSY.</b>  | A. Another filtration cycle is still in process.<br>B. Computer error.   | A. Wait until the previous filtration cycle ends to start another filtration cycle or until the MIB board has reset. This may take up to one minute.<br>B. If filter busy is still displayed with no activity, ensure the filter pan is empty and remove and restore <b>ALL</b> power to the fryer.  |
| <b>M3000 displays IS DRAIN CLEAR?</b>                                       | Clogged drain or Oil Level Sensor is malfunctioning.   | The oil level sensor detects that oil is not draining possibly due to clogged drain. Ensure drain is not clogged. If drain is not clogged, see oil level sensor troubleshooting on page 1-47.  |
| <b>M3000 displays OIL SENSOR FAIL</b>                                       | Oil level sensor is not functioning properly.  | Check the oil level sensor and ensure that it is working properly.   |
| <b>M3000 displays SERVICE REQUIRED followed by the error .</b>              | An error has occurred.   | Press YES to silence alarm. The error is displayed three times. See list of issues in section 1.17.3. Fix issue. The computer displays <b>SYSTEM ERROR FIXED? YES/NO</b> . Press YES. Computer displays <b>ENTER CODE</b> . Enter 1111 to clear error code. Pressing NO will allow the fryer to cook but error will be redisplayed every 15 minutes. |
| <b>M3000 display is in wrong temperature scale (Fahrenheit or Celsius).</b> | Incorrect display option programmed.   | See section 1.17.2 on page 1-45 to change temperature scale.   |
| <b>M3000 displays CHANGE FILTER PAD.</b>                                    | Filter error has occurred, filter pad clogged, 24 hour filter pad change prompt has occurred or change filter pad was ignored on a prior prompt. | Change the filter pad and ensure the filter pan has been removed from the fryer for a minimum of <b>30</b> seconds. Do <b>NOT</b> ignore <b>CHANGE FILTER PAD</b> prompts.   |
| <b>M3000 displays HOT-HI-1.</b>   | Frypot temperature is more than 410°F (210°C) or, in CE countries, 395°F (202°C).  | This is an indication of a malfunction in the temperature control circuitry, including a failure of the high-limit thermostat.   |
| <b>M3000 displays HI-LIMIT.</b>   | Computer in high-limit test mode.  | This is displayed only during a test of the high-limit circuit and indicates that the high-limit has opened properly.  |

| <b>Problem</b>  | <b>Probable Causes</b>   | <b>Corrective Action</b>   |
|---|--|--|
| <b>M3000 displays INSERT PAN.</b>   | <ul style="list-style-type: none"> <li>A. Filter pan is not fully inserted into fryer.</li> <li>B. Missing filter pan magnet.</li> <li>C. Defective filter pan switch.</li> </ul>                        | <ul style="list-style-type: none"> <li>A. Pull filter pan out and fully reinsert into fryer.</li> <li>B. Ensure the filter pan magnet is in place and if missing replace.</li> <li>C. If the filter pan magnet is fully against the switch and computer continues to display <b>INSERT PAN</b>, switch is possibly defective.</li> </ul>                                   |
| <b>M3000 displays LOW TEMP alternating with ALT-CYCL.</b>   | Frypot temperature is below 180°F (82°C).  | This display is normal when the fryer is first turned on while in the melt cycle mode. To bypass the melt cycle press and hold either #1 or #2 cook button under the LCD display until a chirp is heard. The computer displays <b>EXIT MELT</b> alternating with <b>YES NO</b> . Press the #1 YES button to exit melt. If the display continues, the fryer is not heating. |
| <b>M3000 displays TEMP PROBE FAILURE.</b>   | <ul style="list-style-type: none"> <li>A. Problem with the temperature measuring circuitry including the probe.</li> <li>B. Damaged computer wiring harness or connector.</li> </ul>                     | <ul style="list-style-type: none"> <li>A. This indicates a problem within the temperature measuring circuitry. Check resistance of probe, if faulty replace probe.</li> <li>B. Swap the computer wiring harness with one known to be good. If problem is corrected, replace the harness.</li> </ul>  |
| <b>M3000 displays REMOVE DISCARD.</b>   | In non-dedicated mode, a product is dropped that has a different setpoint that the current vat temperature.  | Remove and discard product. Press a cook button under the display with the error to remove the error. Reset the setpoint of the vat before trying to cook product.   |
| <b>M3000 displays HEATING FAILURE.</b>  | Failed computer, failed gas valve, open drain valve, failed interface board, open high-limit thermostat.   | Turn off the vat with the issue. The error is displayed if the fryer loses its ability to heat oil. Common issues are open drain valve or closed or failed gas valves. It sometimes is seen when air is in the gas line. It is also displayed when the oil temperature is above 450°F (232°C) and the high-limit thermostat has opened, halting the heating of the oil.    |
| <b>M3000 displays HI 2 BAD.</b>   | Computer in high-limit test mode.  | This is displayed during a test of the high-limit circuit to indicate if the high-limit has failed.  |
| <b>M3000 displays HELP HI-2 or HIGH LIMIT FAILURE.</b>  | Failed high-limit.   | This is displayed to indicate the high-limit has failed.   |
| <b>Fryer filters after each cook cycle.</b>   | Filter after setting incorrect or software update issue.   | Overwrite the filter after setting by re-entering the filter after value in level two. Ensure that the down arrow is pressed after entering the value to save the setting (see section 4.13.5 on page 4-36 in the BIGLA330 IO Manual).   |
| <b>M3000 displays LOW TEMP, heating indicator cycles on and off normally but fryer does not heat.</b> | <ul style="list-style-type: none"> <li>A. Dirty oil level sensor</li> <li>B. Failed computer.</li> <li>C. Damaged computer wiring harness.</li> <li>D. Open connection in high-limit circuit.</li> </ul> | <ul style="list-style-type: none"> <li>A. Clean carbon build up off oil level sensor using a no scratch pad.</li> <li>B. Replace computer.</li> <li>C. Replace computer wiring harness.</li> <li>D. Check high limit circuit starting at the control box connector working to the high-limit.</li> </ul>   |

| Problem   | Probable Causes   | Corrective Action   |
|---|---|---|
| M3000 displays software for only M3000 or MIB but not all boards. | Loose or damaged harness  | Check that all harnesses between M3000's, MIB, AIF and ATO are secure. Ensure 24VDC is present on pins 5 & 6 of J2 on MIB board and on J4 or J5 of AIF board. Check for loose or broken pins/wires. If the problem persists, swap out computer from one bank to another and cycle power on the fryer. |
| M3000 displays 15 VAT FULL? YES NO.                               | A filter error has occurred due to dirty or clogged filter pad or paper, clogged filter pump, filter pump thermal overload, improperly installed filter pan components, worn or missing O-rings, cold oil or an actuator problem. | Follow the steps in the flowchart in section 1.17.6.  |

### 1.17.2 M3000 Useful Codes

To enter any of the following codes: Press and hold ◀ and ▶ simultaneously for **TEN** seconds; three chirps sound. The computer displays **TECH MODE**. Enter the codes below to perform the function.

- **1658 – Change from F° to C°** The computer displays **OFF**. Turn the computer on and check temperature to see the temperature scale. If the desired scale is not displayed, repeat.
- **3322 – Reset Factory Menu** The computer displays **COMPLETE** and then **OFF**. (**NOTE:** This will delete any hand-entered menu items).
- **1650 – Enter Tech Mode.** See section 1.17.3 below to reset passwords and change filter pad time.
- **1212 – Switch between Domestic Menu and International Menu.** The computer displays **COMPLETE** and then **OFF**. (**NOTE:** This will delete any hand-entered menu items).

The following codes require the removal and reinsertion of the J3 locator plug on the rear of the computer before entering the code.

- **1000 – Reset CALL TECH Message** - Disconnect board locator plug (J3). Reinsert plug. Enter **1000**. Computer display switches to **OFF**. Remove and then restore power to the computer using the 20-pin plug. If this error is displayed, replace the computer.
- **9988 – Reset BADCRC Message** - Disconnect board locator plug (J3). Reinsert plug. Enter **9988**. Computer display switches to **OFF**. Remove and then restore power to the computer using the 20-pin plug. Replace the computer.

The following codes are entered when prompted to do so or from an energy misconfigured exception error.

- **1111 – Reset SERVICE REQUIRED Message** – Enter when the issue is fixed and prompted to enter.
- **1234** – Enter **SETUP MODE** from energy misconfigured exception error (This usually can be done without pressing the filter buttons if an error is displayed.)

### PASSWORDS

To enter level one, level two passwords: Press and hold the **TEMP** and **INFO** buttons simultaneously until level 1 or level 2 is displayed. Release the buttons and **ENTER CODE** appears.

- **1234 – Fryer Setup, Level One and Level Two**
- **4321 – Usage Password** (resets usage statistics).

### 1.17.3 Tech Mode

Tech mode allows technicians to reset all passwords set in levels one and two and change when the fryer calls for a filter pad change. The default is 25 hours.

1. Press and hold ◀ and ▶ simultaneously for **TEN** seconds until three chirps sound and **TECH MODE** is displayed.
2. Enter **1650**.
3. The computer displays **CLEAR PASSWORDS**.
4. Press the ✓ (1) button to accept selection and clear the passwords.

5. The computer displays **CLEAR PASSWORDS** on the left and **COMPLETE** on the right. This clears any passwords set up under levels one and two.
6. Press the ▼ button to toggle to **FILTER PAD TIME** on the left and **25** on the right. (25 hours is the default time to change the pad)
7. Press the ✖ (2) button to accept changes and exit.
8. The computer displays **OFF**.

#### 1.17.4 Service Required Errors

A **SERVICE REQUIRED** error alternating with **YES** displays on the computer. After **YES** is pressed the alarm is silenced. The computer displays an error message from the list below three times with the location of the error. Then the computer displays **SYSTEM ERROR FIXED? YES/NO**. If **yes** is chosen, enter code 1111. If **NO** is chosen the system returns to cook mode for 15 minutes then redisplay error until issue is fixed.

Pressing the MIB reset button during any filter function will generate a “**SERVICE REQUIRED**” error.

#### 1.17.5 Error Log Codes

Refer to page 1-49, level 2 program for access to the E-log. The ten most recent errors are listed from A-J, with A being the most recent error.

| Code | ERROR MESSAGE                                  | EXPLANATION   |
|------|--|---|
| E03  | ERROR TEMP PROBE FAILURE                       | Temp probe reading out of range   |
| E04  | HI 2 BAD                                       | High limit reading is out of range.   |
| E05  | HOT HI 1                                       | High limit temperature is past more than 410°F (210°C), or in CE countries, 395°F (202°C)   |
| E06  | HEATING FAILURE                                | A component has failed in the high limit circuit such as computer, interface board, contactor or open-high limit.   |
| E07  | ERROR MIB SOFTWARE                             | Internal MIB software error   |
| E08  | ERROR ATO BOARD                                | MIB detects ATO board connection lost; ATO board failure  |
| E09  | ERROR PUMP NOT FILLING                         | Oil not returning to vat quickly. Possible problems: dirty pad, bad or missing O-rings, tripped or defective filter pump, actuators or linkage.                                 |
| E10  | ERROR DRAIN VALVE NOT OPEN                     | Drain valve failed to open; the valve's position is unknown.  |
| E11  | ERROR DRAIN VALVE NOT CLOSED                   | Drain valve failed to close; the valve's position is unknown.   |
| E12  | ERROR RETURN VALVE NOT OPEN                    | Return valve failed to open; the valve's position is unknown.   |
| E13  | ERROR RETURN VALVE NOT CLOSED                  | Return valve failed to close; the valve's position is unknown.  |
| E14  | ERROR AIF BOARD                                | MIB detects AIF missing; AIF board failure  |
| E15  | ERROR MIB BOARD                                | Cooking computer detects MIB connections lost; Check software version on each computer. If versions are missing, check CAN connections between each computer; MIB board failure |
| E16  | ERROR AIF PROBE                                | AIF RTD reading out of range  |
| E17  | ERROR ATO PROBE                                | ATO RTD reading out of range  |
| E19  | M3000 CAN TX FULL                              | Connection between computers lost   |
| E20  | INVALID CODE LOCATION                          | SD card removed during update   |
| E21  | FILTER PAD PROCEDURE ERROR (Change Filter Pad) | 25 hour timer has expired or dirty filter logic has activated   |
| E22  | OIL IN PAN ERROR                               | The MIB has reset the oil in pan flag.  |
| E23  | CLOGGED DRAIN (Gas)                            | Vat did not empty during filtration   |
| E24  | OIL SENSOR FAILED (Gas)                        | Oil is back sensor failed.  |
| E25  | RECOVERY FAULT                                 | Recovery time exceeded maximum time limit.  |

### 1.17.6 M3000 Filter Error Flowchart

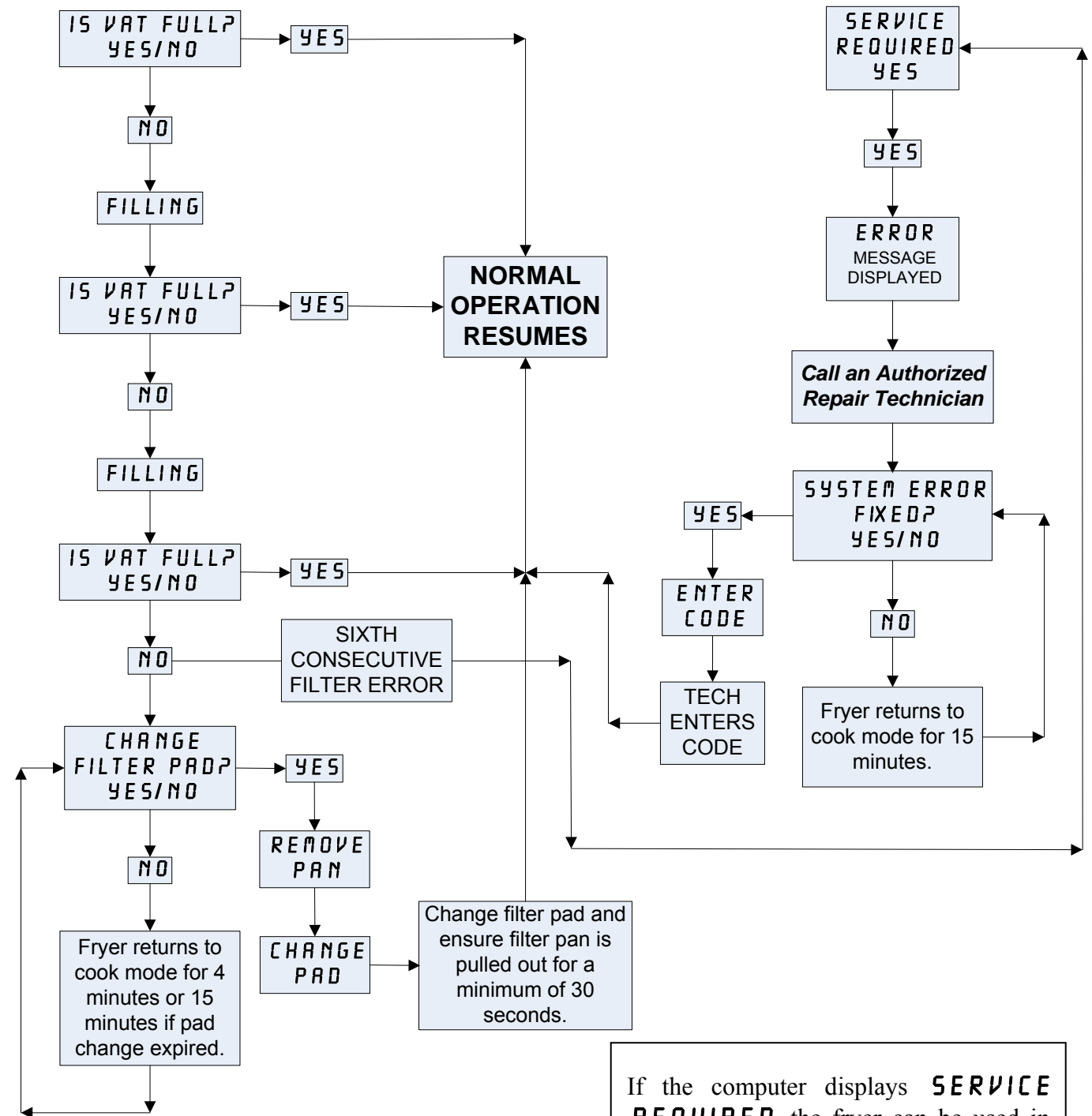

This chart follows the process of clearing a filtration issue. The prompt is displayed when any of the following occur:

1. a clogged filter pad,
2. a tripped or defective filter pump,
3. a leaky O-ring on the pick-up tube,
4. a failed drain valve/actuator, or
5. a failed return valve/actuator.

If the computer displays **SERVICE REQUIRED**, the fryer can be used in most cases by answering **NO** when the prompt for **SYSTEM ERROR FIXED? YES NO** is displayed. The message repeats every 15 minutes until the issue is repaired and error cleared by a technician. To clear the error, enter 1111 after answering **YES** when **SYSTEM ERROR FIXED? YES NO** is displayed.



## 1.17.8 M3000 Menu Summary Tree

Reflected below are the major programming sections in the M3000 and the order in which submenu headings will be found under the sections in the Installation and Operation Manual.

|  |                    |
|--|--------------------|
| <b>Adding New Menu Items</b>                     | See section 4.10.2 |
| <b>Storing Menu Items in Product Buttons</b>     | See section 4.10.3 |
| <b>Draining, Refilling, and Disposing of Oil</b> | See section 4.10.4 |

|  |        |
|--|--------|
| Filter Menu .....  | 4.11   |
| [Press and hold ◀ FLTR or FLTR ▶]  |        |
| — Auto Filter  |        |
| — Maint Filter   |        |
| — Dispose  |        |
| — Drain to Pan   |        |
| — Fill Vat from Drain Pan  |        |
| — Fill Vat from Bulk (Bulk Only)   |        |
| — Pan to Waste (Bulk Only)   |        |
| Programming .....  |        |
| Level 1 Program .....  | 4.12   |
| [Press and hold TEMP and INFO buttons, 2 beeps, displays Level 1, enter 1234]    |        |
| Product Selection .....  | 4.10.2 |
| — Name   |        |
| — Cook Time  |        |
| — Temp   |        |
| — Cook ID  |        |
| — Duty Time 1  |        |
| — Duty Time 2  |        |
| — Qual Tmr   |        |
| — AIF Disable  |        |
| — Assign Btn   |        |
| AIF Clock .....  | 4.12.1 |
| — Disabled   |        |
| — Enabled  |        |
| Deep Clean Mode .....  | 4.12.2 |
| High-Limit Test .....  | 4.12.3 |
| Fryer Setup .....  | 4.9    |
| Level 2 Program (Manager Level) .....  | 4.13   |
| [Press and hold TEMP and INFO buttons, 3 beeps, displays Level 2, enter 1234]    |        |
| Prod Comp Sensitivity for product .....  | 4.13.1 |
| E-Log Log of last 10 error codes .....   | 4.13.2 |
| Password Setup Change passwords .....  | 4.13.3 |
| — Setup [enter 1234]   |        |
| — Usage [enter 4321]   |        |
| — Level 1 [enter 1234]   |        |
| — Level 2 [enter 1234]   |        |
| Alert Tone Volume and Tone .....   | 4.13.4 |
| — Volume 1-9   |        |
| — Tone 1-3   |        |
| Filter After Sets number of cooks before filter prompt .....                     | 4.13.5 |
| Filter Time Sets amount of time between filter cycles .....                      | 4.13.6 |
| Tech Mode .....  |        |
| [Press and hold ◀ and ▶ for 10 seconds, 3 beeps, displays TECH MODE, enter 1550] |        |
| — Clear Passwords  |        |
| — Filter Pad Time  |        |
| Info Mode .....  | 4.14   |
| [Press and hold INFO for 3 seconds, displays Info Mode]                          |        |
| Full/Split Vat Configuration .....   |        |
| — Filter Stats .....   | 4.14.1 |
| — Review Usage .....   | 4.14.2 |
| — Last Load .....  | 4.14.3 |

### 1.17.9 M3000 Board Pin Positions and Harnesses

| Connector | From/To                            | Harness PN   | Pin # | Function       | Voltage | Wire Color |
|-----------|------------------------------------|--|-------|----------------|---------|------------|
| J1        | SD Card                            |  |       |                |         |            |
| J2        | Interface Board to Computer        | 8074199<br>SMT Computer to Interface Board Harness | 1     | 12VAC In       | 12VAC   | Black      |
|           |                                    |  | 2     | Ground         |         |            |
|           |                                    |  | 3     | 12VAC In       | 12VAC   |            |
|           |                                    |  | 4     | FV Heat Demand |         |            |
|           |                                    |  | 5     | V Relay        | 12VDC   |            |
|           |                                    |  | 6     | DV Heat Demand |         |            |
|           |                                    |  | 7     | R/H B/L        | 12VDC   |            |
|           |                                    |  | 8     | Analog Ground  |         |            |
|           |                                    |  | 9     | L/H B/L        | 12VDC   |            |
|           |                                    |  | 10    | ALARM          |         |            |
|           |                                    |  | 11    | Sound Device   | 5VDC    |            |
|           |                                    |  | 12    | ALARM          |         |            |
|           |                                    |  | 13    | FV Probe       |         |            |
|           |                                    |  | 14    | Common Probes  |         |            |
|           |                                    |  | 15    | DV Probe       |         |            |
| J3        | Interface Board Ground to Computer | Computer Locator Harness                           | 1     | Vat #1         |         | Black      |
|           |                                    |  | 2     | Vat #2         |         |            |
|           |                                    |  | 3     | Vat #3         |         |            |
|           |                                    |  | 4     | Vat #4         |         |            |
|           |                                    |  | 5     | Vat #5         |         |            |
|           |                                    |  | 6     | Ground         |         |            |
| J4        | <b>Not Used</b>                    |  |       |                |         |            |
| J6        | Next M3000 J7 or Network Resistor  | 8074546<br>Computer Communication Harness          | 1     | Ground         |         | Black      |
|           |                                    |  | 2     | CAN Lo         |         | Red        |
|           |                                    |  | 3     | CAN Hi         |         | White      |
|           |                                    |  | 4     |                |         |            |
|           |                                    |  | 5     |                |         |            |
|           |                                    |  | 6     |                |         |            |
| J7        | MIB J1 or previous M3000 J6        | 8074546<br>Computer Communication Harness          | 1     | Ground         |         | Black      |
|           |                                    |  | 2     | CAN Lo         |         | Red        |
|           |                                    |  | 3     | CAN Hi         |         | White      |
|           |                                    |  | 4     |                |         |            |
|           |                                    |  | 5     |                |         |            |
|           |                                    |  | 6     |                |         |            |

## 1.18 Loading and Updating Software Procedures

Updating the software takes approximately 30 minutes. The software only needs to be loaded in **ONE** computer and it will update **all** the computers and boards in the system. To update the software, follow these steps carefully:

1. Switch all computers to **OFF**. Press the TEMP button to check current M3000/MIB/AIF/ATO software version.
2. Remove the bezel and remove the two screws on the left side cover plate of the M3000 board.
3. With the computer folded down, insert the SD card, with the contacts facing down and the notch on the bottom right (see Figure 26 and 27), into the slot on the left side of the M3000.
4. Once inserted, **UPGRADE IN PROGRESS** appears on the left display and **WAIT** on the right.
5. The display then changes to **CC UPDATING** on the left and the percentage completed appears on the right. The display counts up to 100 on the right, changing to a flashing **BOOT**. **DO NOT REMOVE THE CARD UNTIL THE DISPLAY PROMPTS TO DO SO IN STEP 8.**
6. Then **UPGRADE IN PROGRESS** is displayed on the left display and **WAIT** on the right again followed by **COOK HEX, MIB HEX, AIF HEX** ending with **ATO HEX** displayed on the left and the percentage complete on the right.
7. The display then changes to **REMOVE SD CARD** on the left and **100** on the right.
8. Remove the SD card using the fingernail slot on the top of the SD card.
9. Once the SD card is removed the display changes to **CYCLE POWER**.
10. Cycle the control power using the hidden reset switch behind the right control box. **ENSURE THE SWITCH IS HELD FOR 10 SECONDS. WAIT ANOTHER 20 SECONDS UNTIL THE MIB BOARD HAS FULLY RESET BEFORE CONTINUING.**
11. An **EXCEPTION MISCONFIGURED ENERGY TYPE** error may appear on the left computer while a flashing **BOOT** is displayed on the remaining computers while the program is transferred. If this happens, enter 1234 on the left computer. The display changes to **LANGUAGE** on the left and **ENGLISH** on the right. To change the entry use the **< FLTR** and **FLTR >** buttons. To navigate to the next field, use the **▼INFO** button. Once all parameters have been setup, press **\* (2)** button to exit. **SETUP COMPLETE** is displayed.
12. When the update is complete the M3000 displays **OFF**. The MIB display will remain blank while software is loading, changing to show the vat numbers. Once the LED's stop blinking, the MIB board will display **R**.
13. Cycle the control power using the hidden reset switch behind the right control box again. **ENSURE THE SWITCH IS HELD FOR 10 SECONDS. WAIT ANOTHER 20 SECONDS UNTIL THE MIB BOARD HAS FULLY RESET BEFORE CONTINUING.**
14. **With the computer displaying OFF, VERIFY software update by pressing the TEMP button to check updated M3000/MIB/AIF/ATO version on each computer. IF ANY BOARDS DID NOT UPDATE, REPEAT THE PROCESS STARTING WITH STEP 3.**
15. Press and hold the two outer filter buttons until **TECH MODE** is displayed.
16. Enter 1650, **CLEAR PASSWORDS** is displayed.
17. Press the INFO button once. **FILTER PAD TIME** is displayed on the left side and **25** is displayed on the right. **IF ANY OTHER NUMBER OTHER THAN 25 IS DISPLAYED, ENTER 25.** This only needs to be performed on one computer.
18. Press the INFO button again.
19. Press the **\* (2)** button to exit.
20. Once the software has been updated and the versions are correct, replace the cover and screws covering the SD card slot.
21. Reinstall the screws attaching the computers and bezel by reversing steps 2 through 5.
22. Perform a forced auto filter cycle on each vat except the fish vat by pressing and holding one of the filter buttons. **FILTER MENU** is displayed changing to **AUTO FILTER**.
23. Press the (1 ✓) button.
24. **FILTER NOW YES/NO** is displayed.
25. Press the (1 ✓) button.
26. **SKIM VAT** is displayed changing to **CONFIRM**.
27. Press the (1 ✓) button. The auto filter cycle should start.
28. Once the filter cycle is complete, repeat on each vat in the fryer.
29. Once all vats have been successfully filtered the software update is finished.

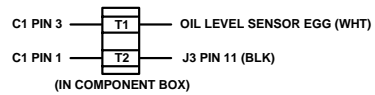
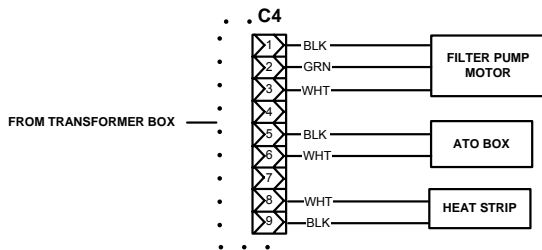
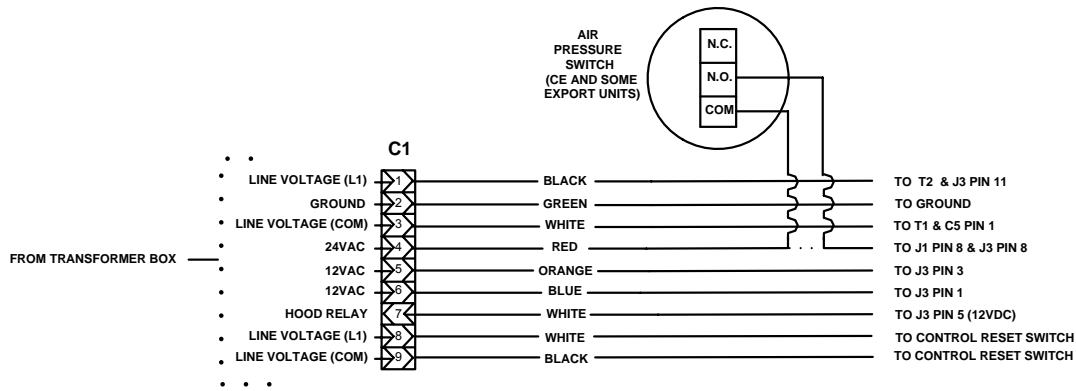

Figure 26

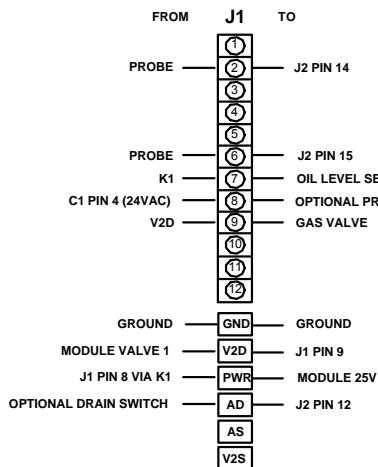

Figure 27

# 1.19 Principal Wiring Connections



## LEFT VAT



## FROM J2 TO

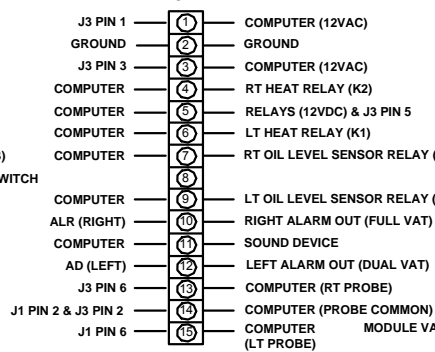

## RIGHT OR FULL VAT

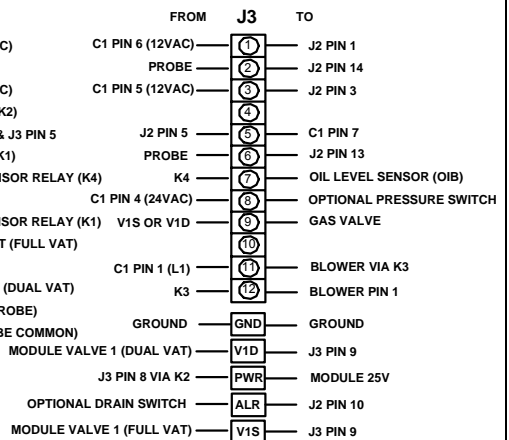

# 1.20 Wiring Diagrams

## 1.20.1 Main BIGLA230 120V/CE/Export

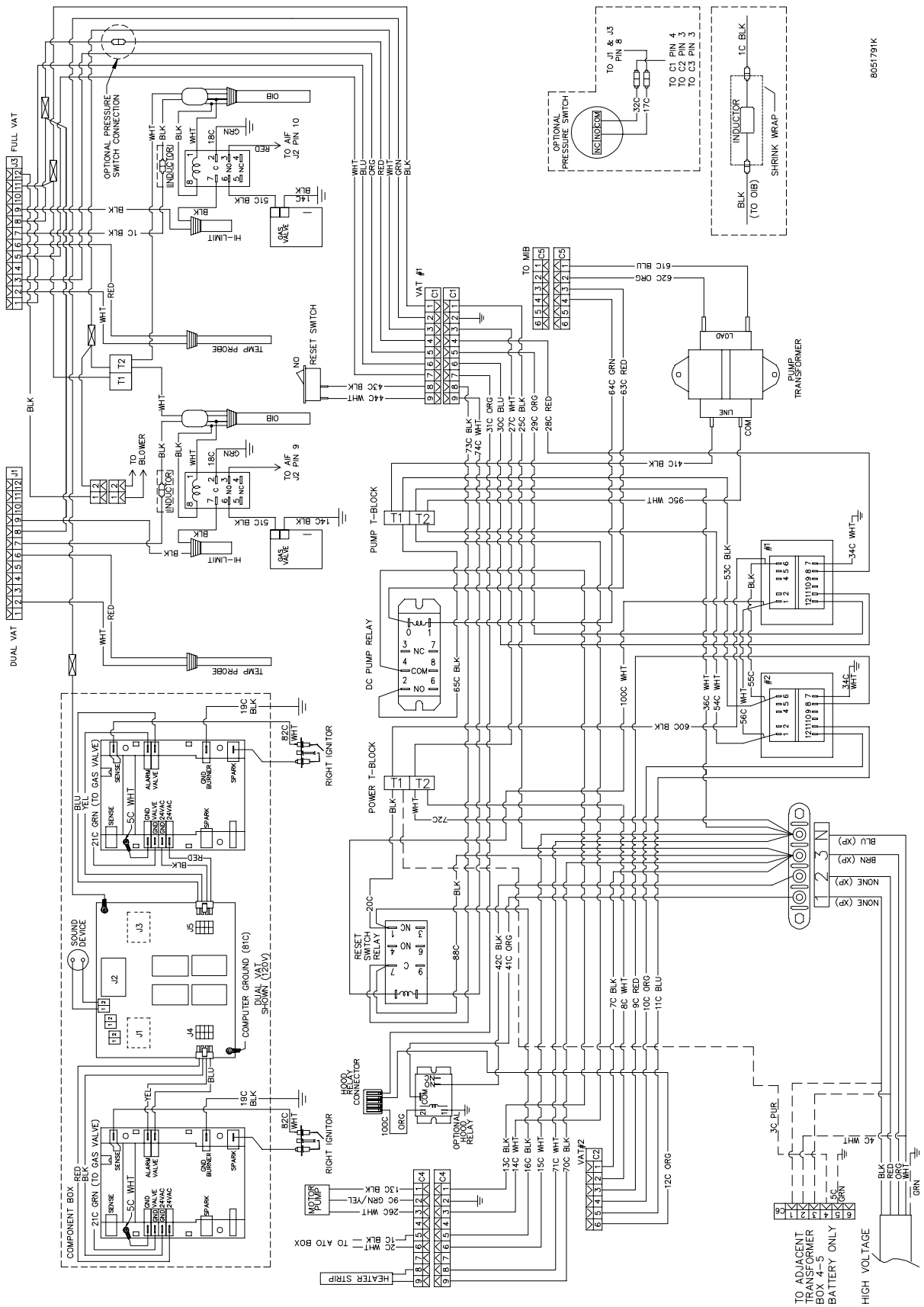



## 1.20.3 Transformer / Filter Boxes

### 1.20.3.1 BIGLA230 and 430 Transformer / Filter Box (Domestic)

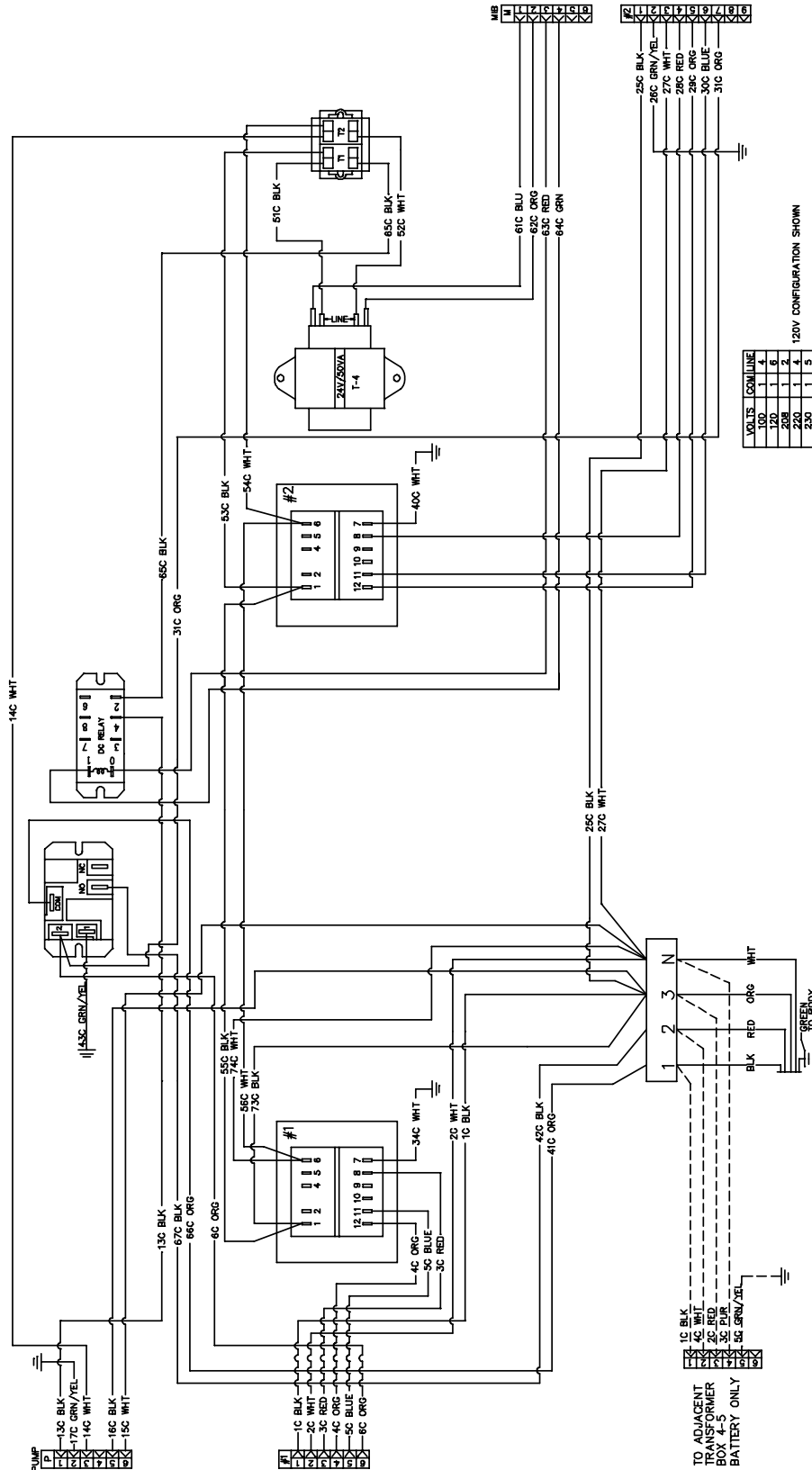

80317140

# 1.20.3.2 BIGLA230 and 430 Transformer / Filter Box (International)

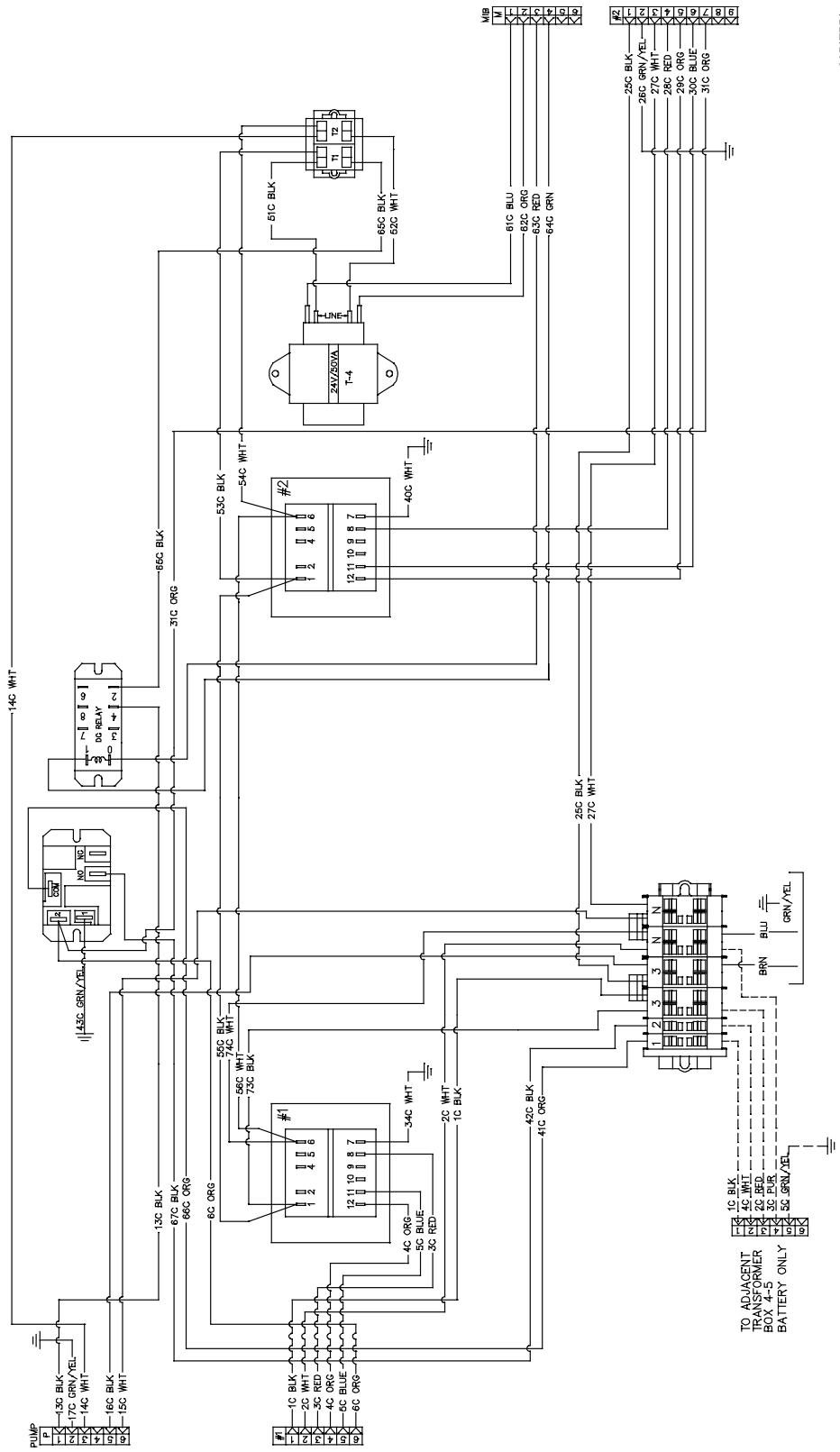

8051753A

# 1.20.3.3 BIGLA330 Transformer / Filter Box (Domestic)

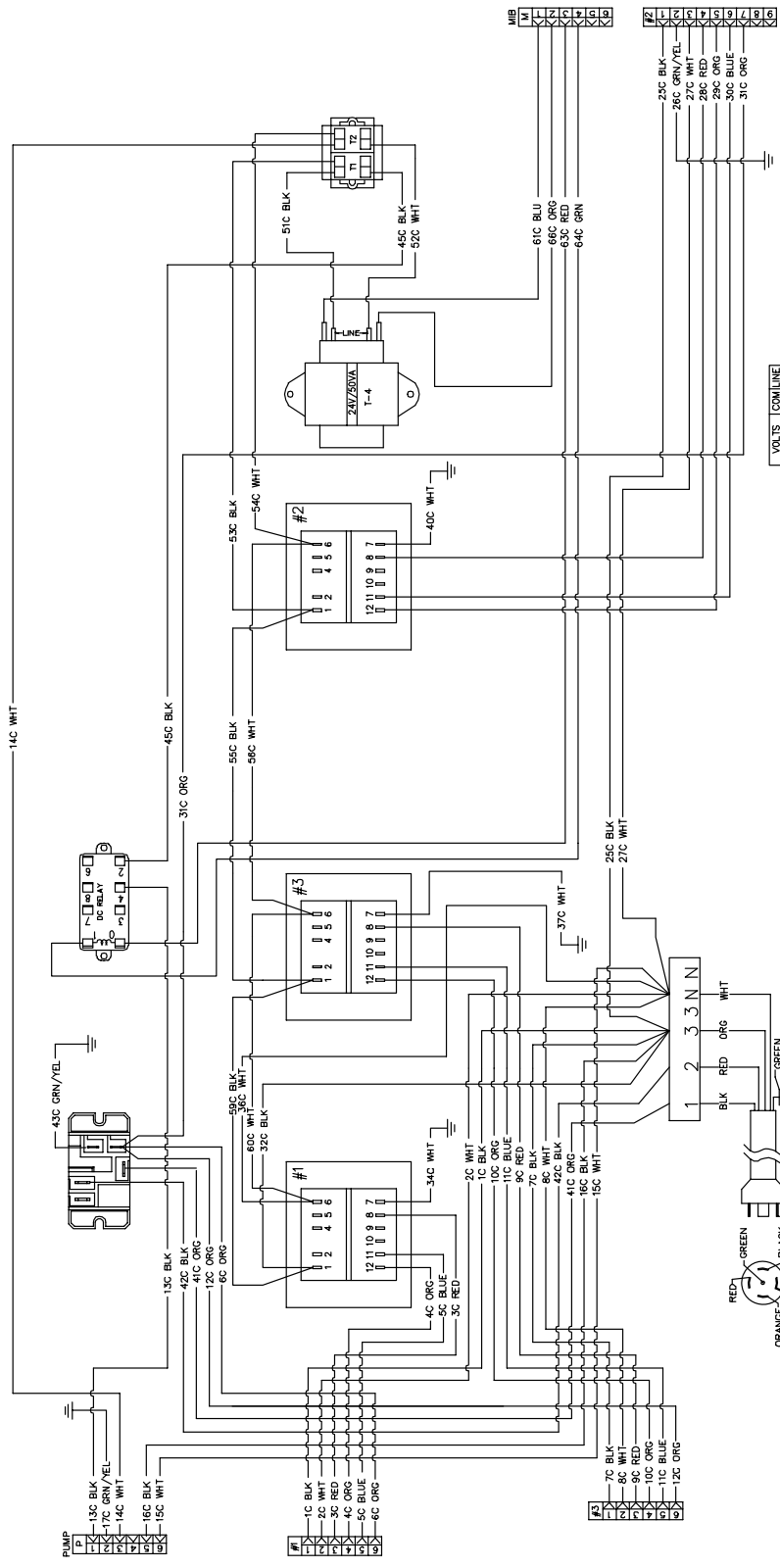

| VOLTS | COMLINE |
|-------|---------|
| 100   | 1 4     |
| 120   | 1 6     |
| 220   | 1 4     |
| 230   | 1 5     |
| 240   | 1 6     |

NOTE: USE TERMINALS 7, 8, 9 FOR 21V OUTPUT

120V CONFIGURATION SHOWN  
 CAUTION: THIS PLUG IS NOT BEING USED IN ITS  
 CONFIGURATION. DO NOT CONNECT TO A STANDARD  
 120/208V SWIRE POWER SUPPLY.

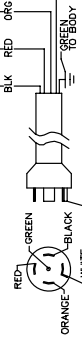

8051718C





## 1.21.2 BIGLA30 Series LOV™ Data Network Flowchart

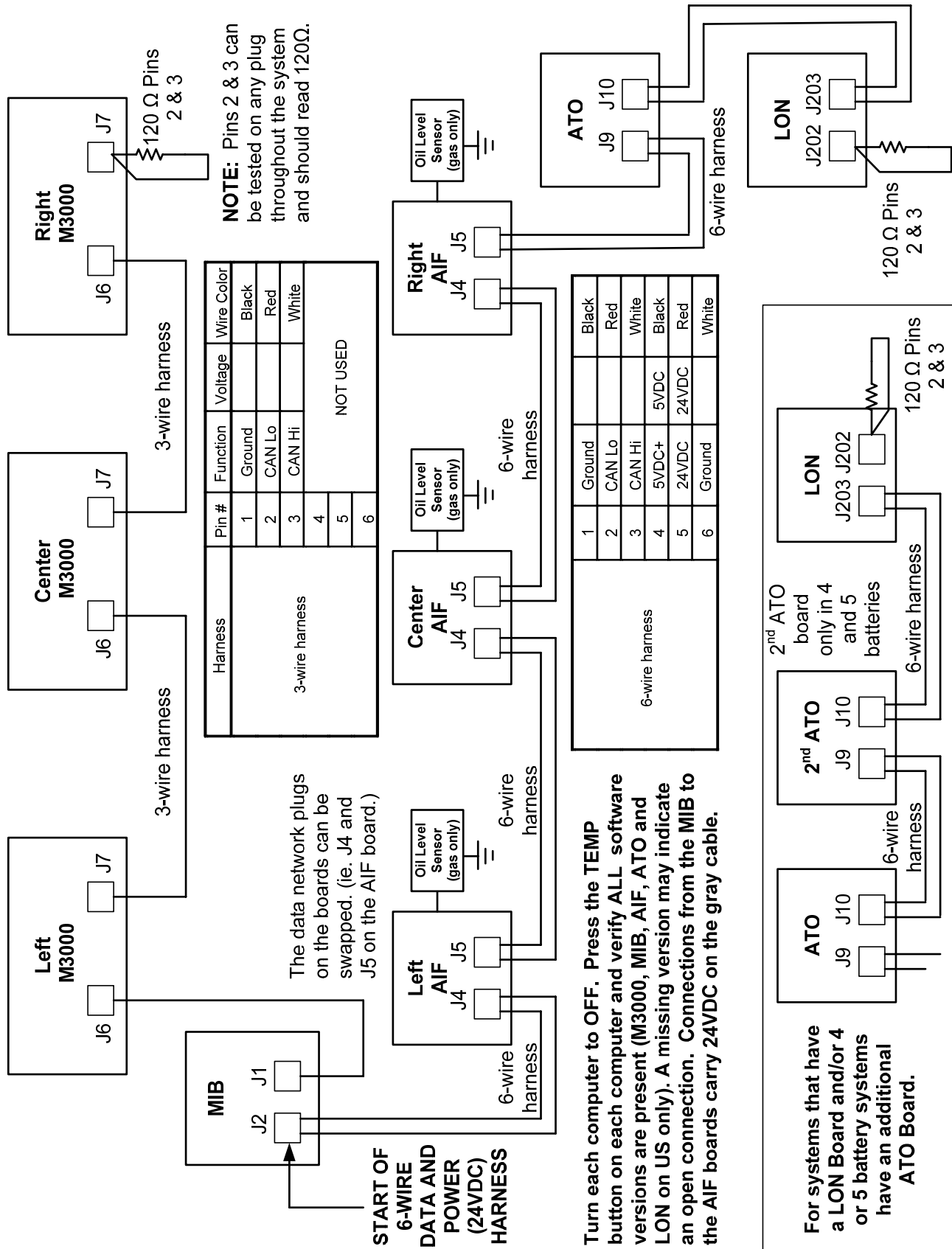

# 1.22 Alternate 7 sec. Time Delay Relay Wiring Diagrams PN 807-4934 220V-250V (Intl. Units), PN 807-4812 120V (US, Canada & Mexico)

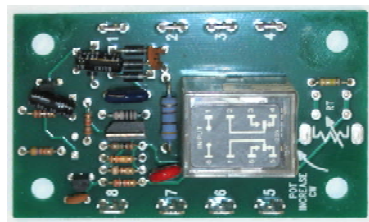
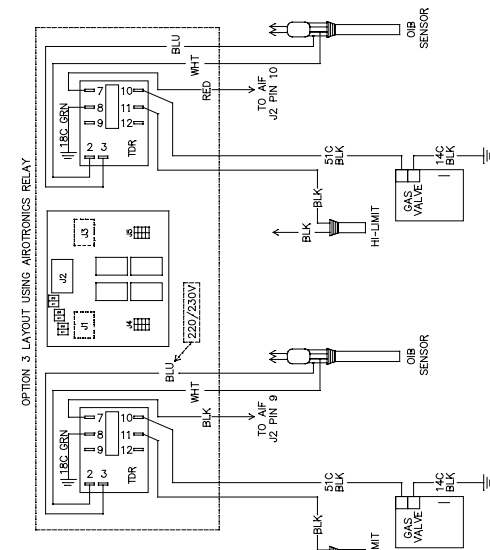
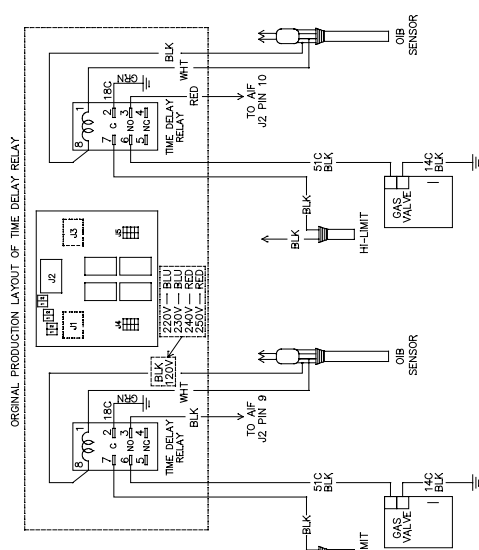
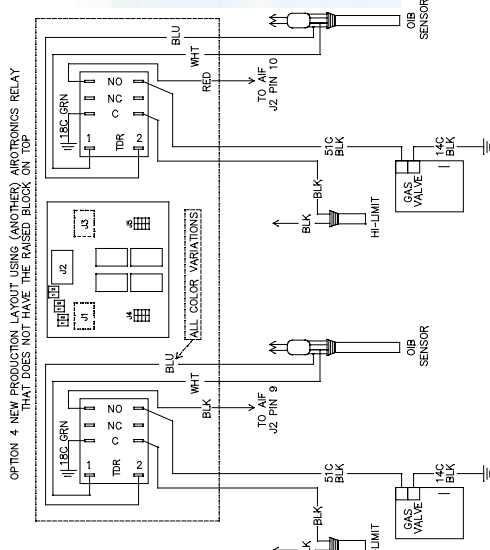
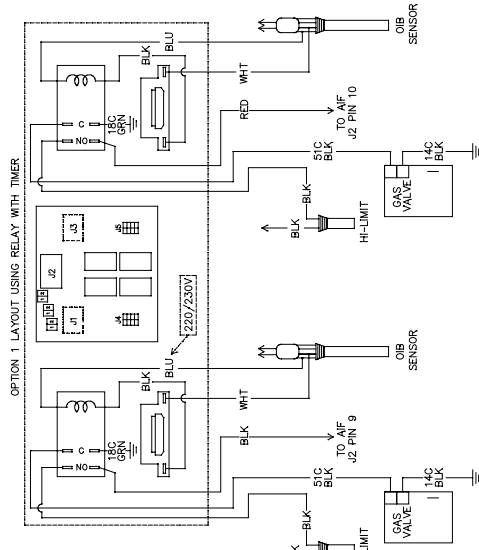
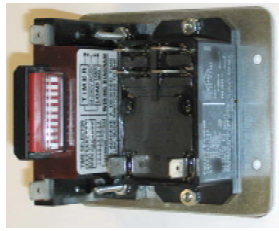

RELAY ORIENTATION MAY BE DIFFERENT IN ACTUAL ASSEMBLY

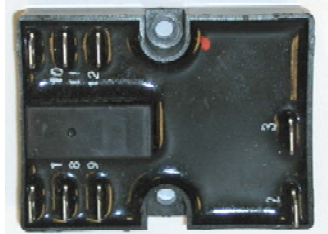

### 1.23 Shortening Melting Unit Wiring Diagram

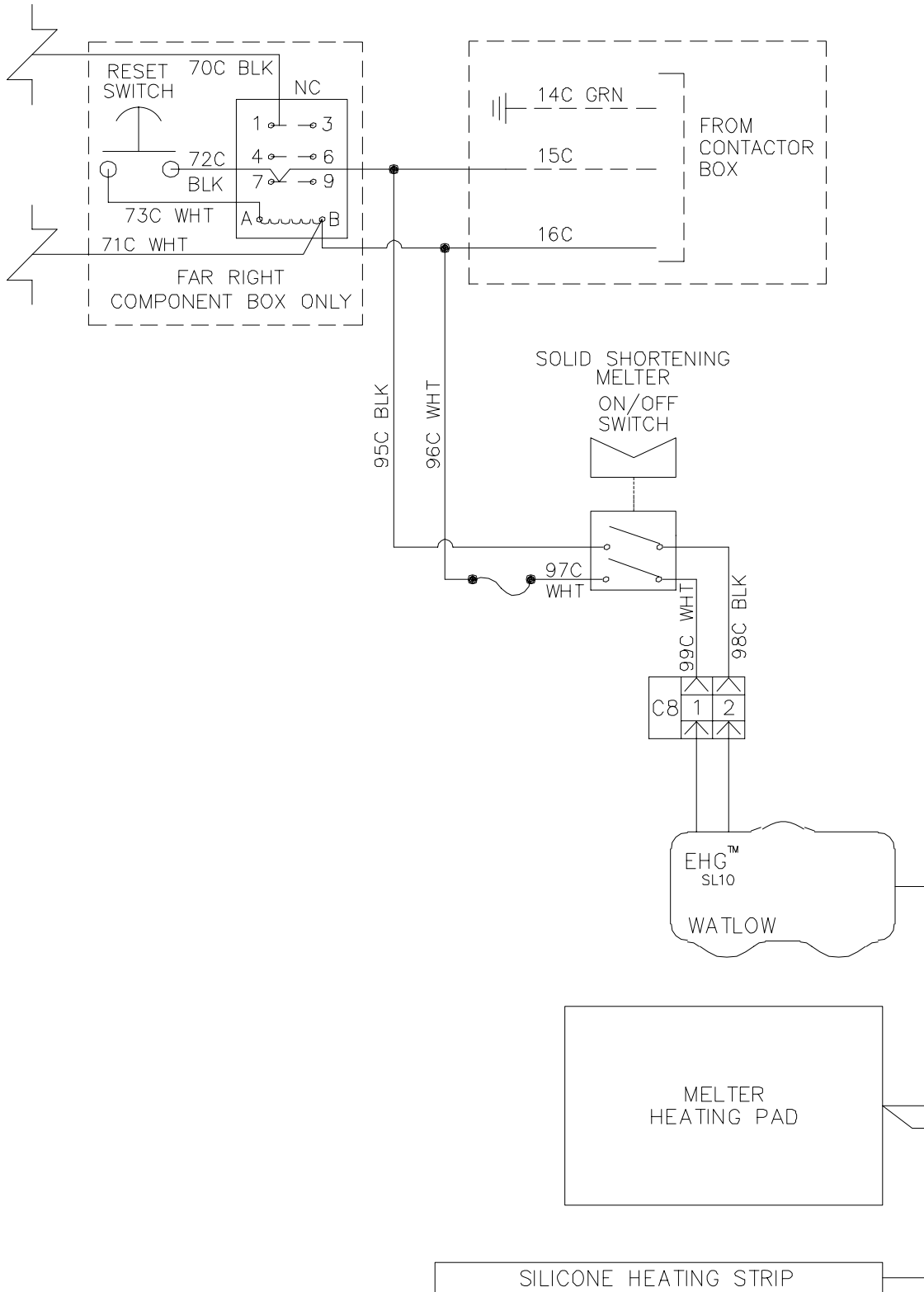

8051889A

# BIGLA30 SERIES LOV™ GAS FRYERS

## CHAPTER 2: PARTS LIST

### 2.1 Accessories

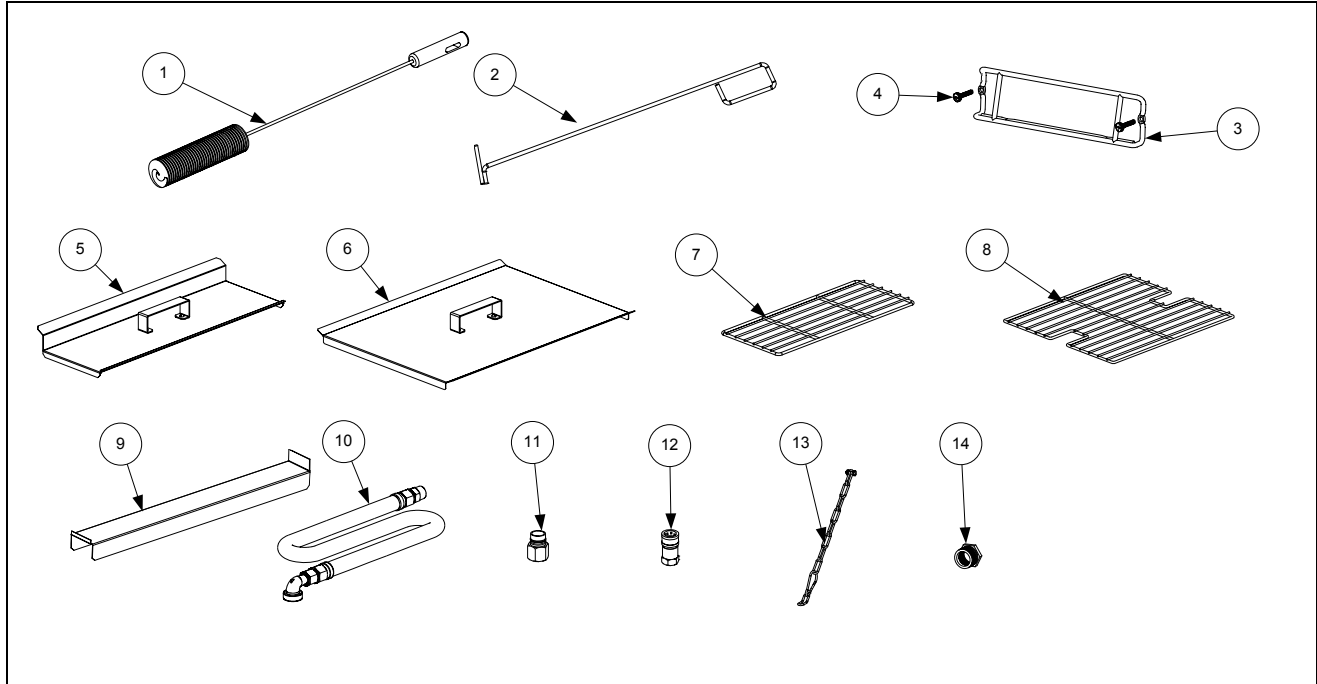

| ITEM | PART #     | COMPONENT  |
|------|------------|--|
| 1    | 803-0398   | Brush, Frypot  |
| 2    | 803-0388   | Fryers Friend LOV™   |
| 3    | 810-2793   | Hanger, Basket   |
| 4    | 809-0171   | Thumbscrew, ¼-20 X 1¾-inch Universal Hood ( <i>use 809-0921 for Spacer</i> ) |
|      | 809-0402   | Thumbscrew, ¼ -20 X ½-inch Cap-N-Splash Hood                                 |
| 5    | 106-8931   | Cover, Frypot, Dual Vat  |
| 6    | 106-8930   | Cover, Frypot, Full Vat  |
| *    | 826-0993SP | Handle Kit, Frypot Cover (includes handle and screws)                        |
| 7    | 803-0372   | Basket Support Rack, Dual Vat  |
| 8    | 803-0375   | Basket Support Rack, Full Vat  |
| *    | 803-0136   | Basket Support Screen, Full Vat (screen w/handle used in place of Item 8)    |
| 9    | 230-2975   | Connecting Strip, Frypot   |
| 10   | 810-0478   | Gas Line, 1-Inch Dormont Flexible  |
|      | 806-1698SP | 36-Inch (for gas line only (w/o Items 11 and 12), use 810-0088)              |
|      | 806-1699   | 48-Inch (for gas line only (w/o Items 11 and 12), use 810-0085)              |
| 11   | 810-0074   | Quick-Disconnect Fitting, 1-Inch Male  |
| 12   | 810-0073   | Quick-Disconnect Fitting, 1-Inch Female                                      |
|      | 810-3745   | Quick Disconnect Fittings, ¾-inch set (includes male and female connectors)  |
| 13   | 826-0900   | Kit, Chain Restraint   |
| 14   | 826-1045   | Bushing, Flexible Gas Line (813-0032)  |
| *    | 826-1157   | Kit, Fuse and Fuse Puller (2 Fuses)  |

\* Not illustrated.

## 2.2 Doors, Sides, Flue Caps, Cap-N-Splash, Top Caps and Casters

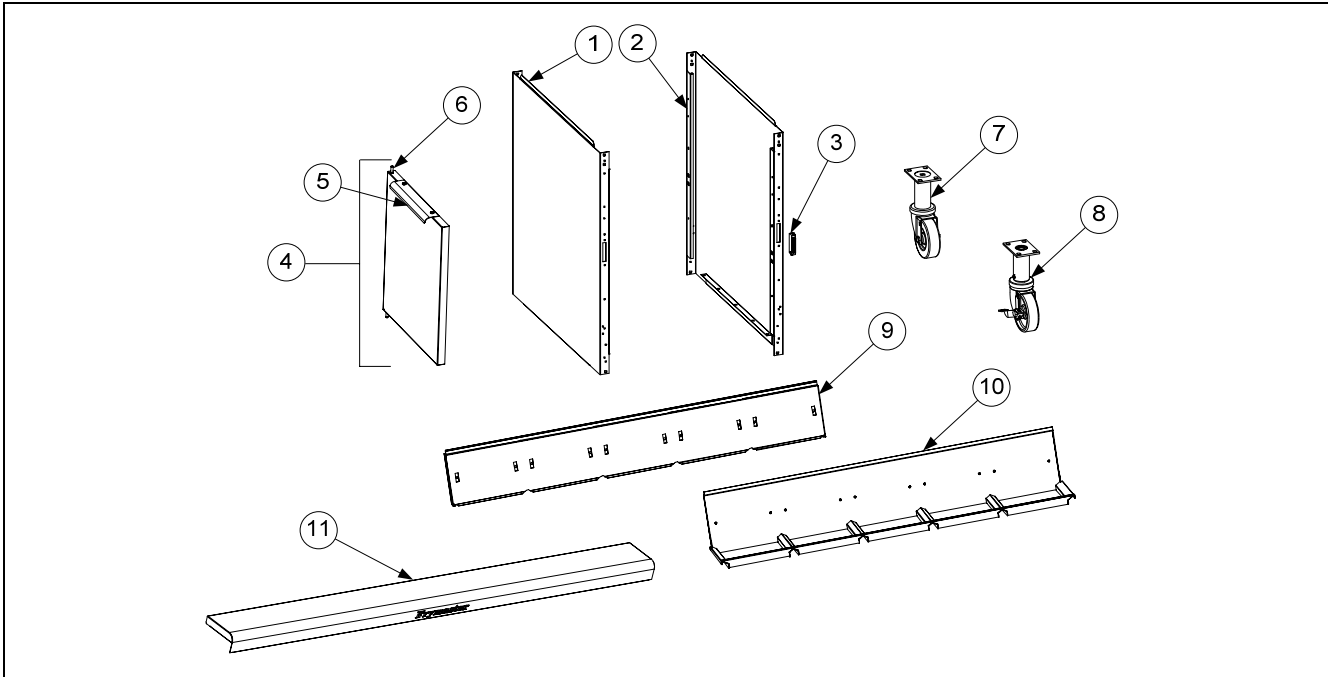

| ITEM | PART #   | COMPONENT   |
|------|----------|---|
| 1    | 231-7908 | Side, Standard Cabinet Left SS (use 221-0323 for Enameled Steel)  |
| 2    | 232-7908 | Side, Standard Cabinet Right SS (use 222-0323 for Enameled Steel)   |
| 3    | 810-1105 | Magnet, Door (vertical) (use 810-2346 for horizontal over filter pan)                                       |
| 4    | 106-4397 | Door, Left or Right (Left shown – move handle to bottom for right) (use 108-0915 for Door w/ Manual Holder) |
| 5    | 230-4960 | Handle, Eurolook Door   |
| 6    | 106-4067 | Pin Assembly, Door  |
| *    | 810-0275 | Spring, Door Pin  |
| *    | 809-0970 | Retaining Ring  |
| *    | 230-7192 | Hinge, Door Lower   |
| 7    | 810-0327 | Caster without Brake  |
| 8    | 810-0944 | Caster with Brake   |
| 9    |          | Flue Cap-Stainless Steel (Use Aluminized steel with Cap-N-Splash)   |
|      | 823-7656 | Two Station Fryer (use 823-6666 for Aluminized Steel)(Use 230-2635 for Hood Strip)                          |
|      | 823-7657 | Three Station Fryer (use 823-6681 for Aluminized Steel) (Use 230-2405 for Hood Strip)                       |
|      | 823-7658 | Four Station Fryer (use 823-6680 for Aluminized Steel) (Use 230-2636 for Hood Strip)                        |
|      | 823-8064 | Five Station Fryer (use 823-8100 for Aluminized Steel) (Use 230-2637 for Hood Strip)                        |
| 10   |          | Cap-N-Splash Assemblies   |
|      | 823-7659 | Two Station Fryer   |
|      | 823-7660 | Three Station Fryer   |
|      | 823-7661 | Four Station Fryer  |
|      | 823-8101 | Five Station Fryer  |
| 11   |          | Top Cap (Cap for 5-staion fryer shown)  |
|      | 108-1522 | Two Station Fryer   |
|      | 108-1523 | Three Station Fryer   |
|      | 108-1524 | Four Station Fryer  |
|      | 108-3030 | Five Station Fryer  |

\* Not illustrated.

## 2.3 Drain Valves and Associated Parts

### 2.3.1 Linear Actuator Drain Valves

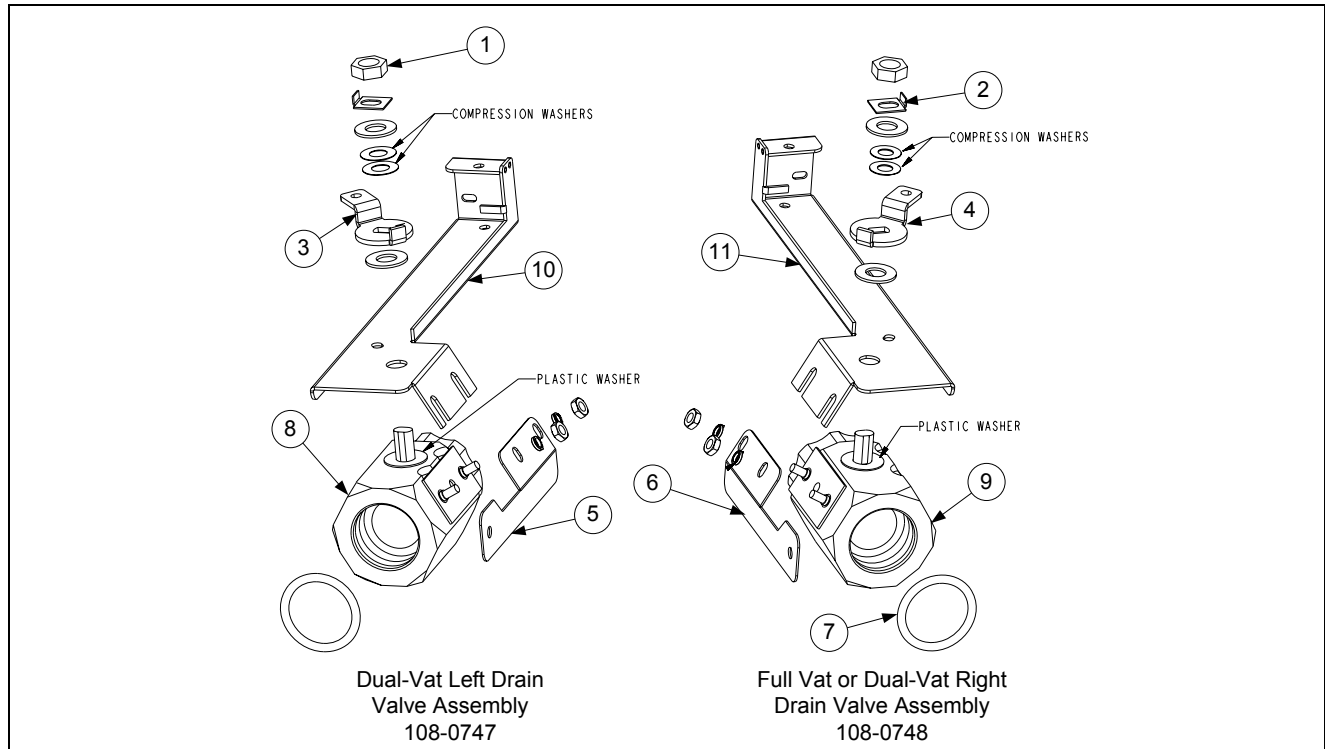

| ITEM | PART #   | COMPONENT                          |
|------|----------|------------------------------------|
| 1    | 809-0540 | Nut, ½-13 2-Way Hex Lock           |
| 2    | 900-2936 | Retainer, Nut Drain Valve          |
| 3    | 231-6294 | Handle, Drain Valve DV Left        |
| 4    | 232-6294 | Handle, Drain Valve FV or DV Right |
| 5    | 221-6306 | Bracket, Drain Valve Lt.           |
| 6    | 222-6306 | Bracket, Drain Valve Rt.           |
| 7    | 816-0544 | O-Ring, Round Drain Seal           |
| 8    | 823-7230 | Valve, 1¼-inch Drain Lt.           |
| 9    | 823-7231 | Valve, 1¼-inch Drain Rt.           |
| 10   | 824-2146 | Mount, Stud Drain Actuator Gas Lt. |
| 11   | 824-2147 | Mount, Stud Drain Actuator Gas Rt. |

### 2.3.2 Rotary Actuator Drain Valves

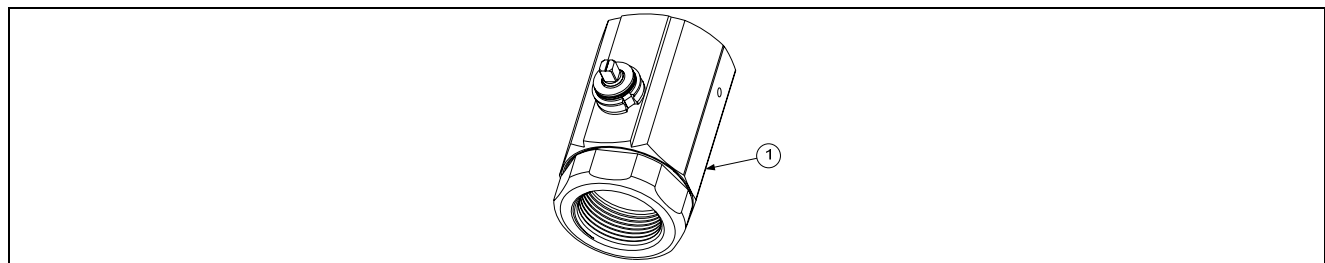

| ITEM | PART #   | COMPONENT                          |
|------|----------|------------------------------------|
| 1    | 810-3755 | Valve, 1¼-inch NPT Rotary Actuator |

## 2.4 Drain Tube Sections and Associated Parts

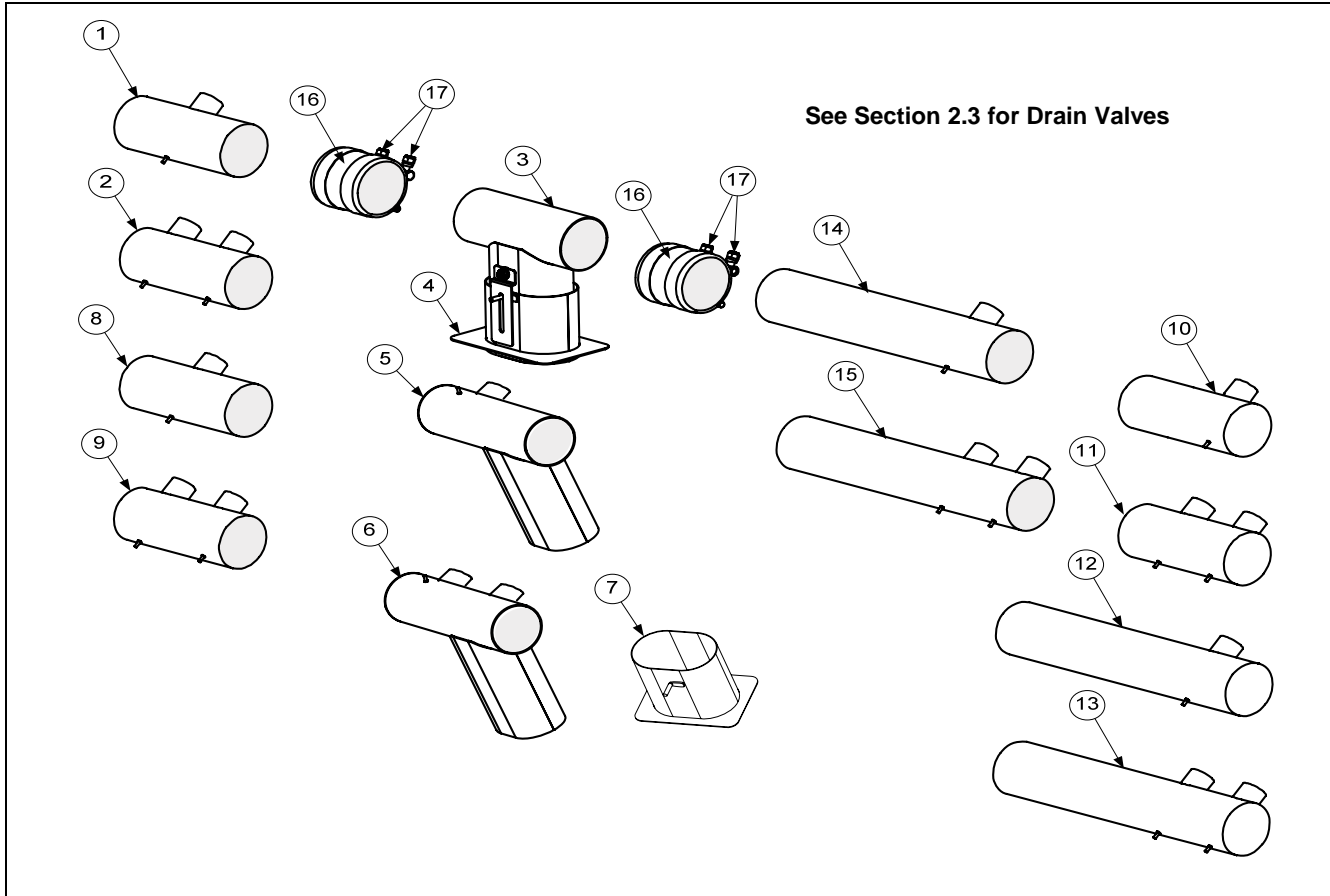

| ITEM | PART #   | COMPONENT   |
|------|----------|---|
| 1    | 823-7323 | Drain Tube, Full-Vat Left Closed/Right End Open             |
| 2    | 823-7325 | Drain Tube, Dual-Vat Left Closed/Right End Open             |
| 3    | 108-0887 | Drain Tube, Dump  |
| 4    | 823-7468 | Shroud, Filter Pan Lid (attaches to item # 3)               |
| 5    | 108-1118 | Drain Tube, Full-Vat 2 Bat. Dump Left Closed/Right End Open |
| 6    | 108-1120 | Drain Tube, Dual-Vat 2 Bat. Dump Left Closed/Right End Open |
| 7    | 823-7480 | Shroud, Filter Pan Lid 2 Bat. (attaches to item # 5 and 6)  |
| 8    | 823-7322 | Drain Tube, Full-Vat Left and Right Open                    |
| 9    | 823-7324 | Drain Tube, Dual-Vat Left and Right Open                    |
| 10   | 823-7330 | Drain Tube, Full-Vat 2 Bat. Left Open/Right End Closed      |
| 11   | 823-7331 | Drain Tube, Dual-Vat 2 Bat. Left Open/Right End Closed      |
| 12   | 823-7329 | Drain Tube, Full-Vat Left Open/Right End Closed             |
| 13   | 823-7326 | Drain Tube, Dual-Vat Left Open/Right End Closed             |
| 14   | 823-7328 | Drain Tube, Full-Vat Left and Right Open                    |
| 15   | 823-7327 | Drain Tube, Dual-Vat Left and Right Open                    |
| 16   | 816-0772 | Sleeve  |
| 17   | 809-0969 | Clamp   |
| *    | 816-0630 | Vinyl Cap   |

\* Not illustrated.

## 2.5 Electronics and Electrical Components

### 2.5.1 High-Limit Thermostat and Temperature Probe

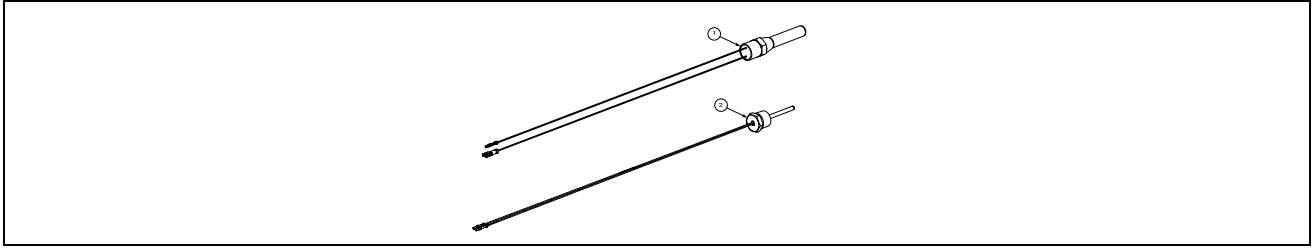

| ITEM | PART #   | COMPONENT   |
|------|----------|---|
| √ 1  | 826-1177 | Thermostat Assembly, HE FM High-Limit 425°F/218°C |
| √ 2  | 826-2900 | Temperature Probe, LOV™                           |

√ Recommended parts.

### 2.5.2 Component Boxes

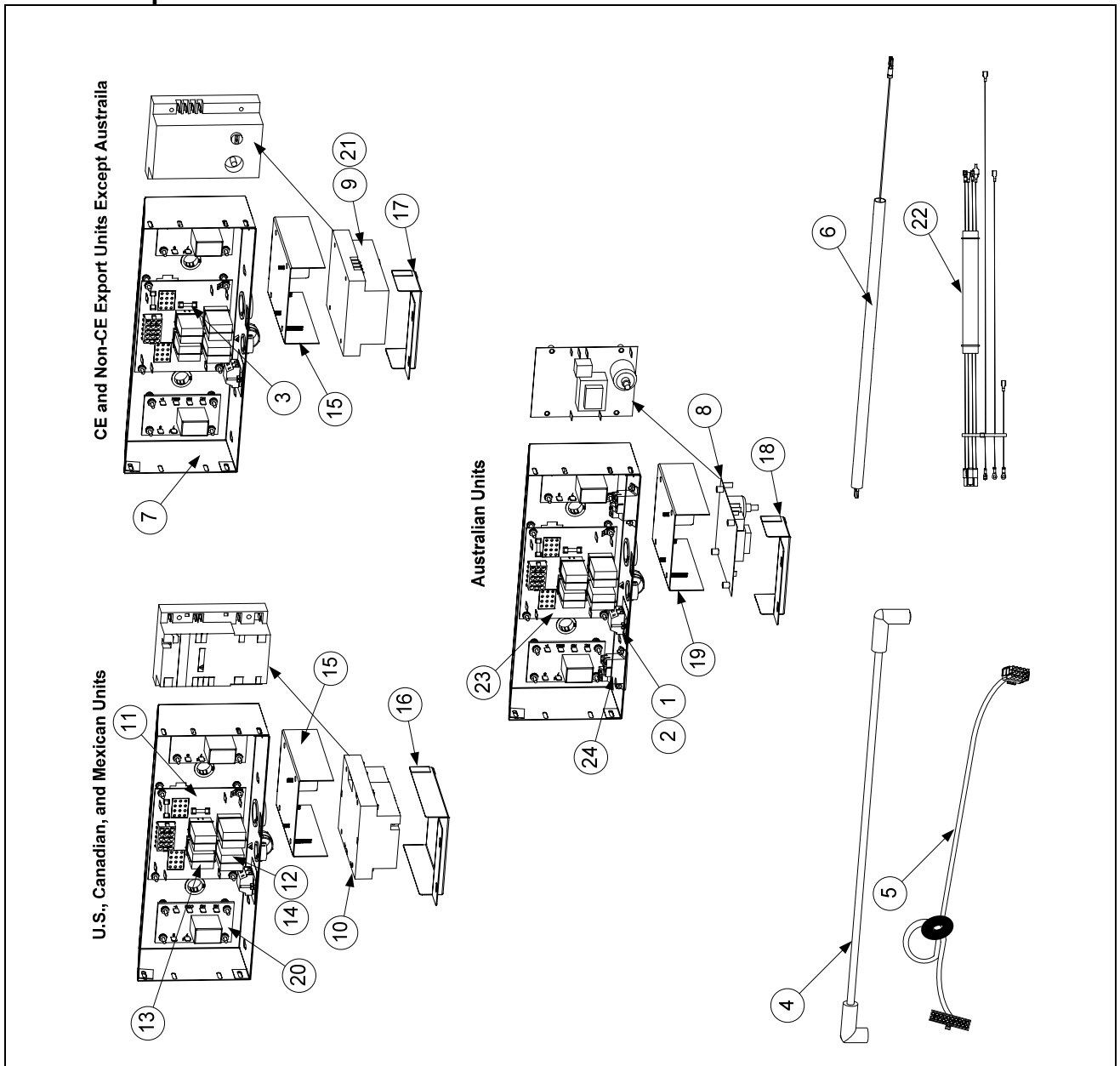

## 2.5.2 Component Boxes cont.

| ITEM | PART #     | COMPONENT  |
|------|------------|--|
| 1    | 810-1164   | Block, One-Piece Screwless Terminal  |
| 2    | 816-0217   | Insulation, Terminal Block Paper   |
| √ 3  | 807-3843   | Fuse 3A 250V Domestic  |
|      | 807-3293   | Fuse 5A 125V <b>International Only</b>   |
| √ 4  | 807-5008   | Cable, 21-inch Ignition – For 807-3366/807-3365 Modules  |
| *    | 807-5009   | Cable, Ignition 19” (CE)   |
| *    | 807-3484   | Connector, Rajah   |
| 5    | 807-4199   | Cable, 20-pin Computer to 15-pin Interface Board - SMT   |
| 6    | 806-6085SP | Wire Assembly, Ignitor   |
| 7    | 220-6102   | Box, One-Piece Component   |
| √ 8  | 807-2971   | Ignition Module, (Australia)   |
| √ 9  | 807-1006   | Ignition Module, CE  |
| √ 10 | 807-3366†  | Ignition Module, Dual-Spark Full-Vat ( <i>Domestic and Non-CE export unit except Australia</i> )   |
| √    | 807-3365†  | Ignition Module, Single-Spark Dual-Vat ( <i>Domestic and Non-CE export unit except Australia</i> ) |
| √ 11 | 826-2264   | Interface Board Kit SMT  |
|      | 807-4330   | Speaker Adapter Harness SMT  |
|      | 807-4343   | Wire Harness, SMT Interface Board to Ignition Module   |
| √ 12 | 807-0833   | Relay, DPDT 5A 12VDC Latch (See <b>NOTE 1.</b> )   |
| √ 13 | 807-0834   | Relay, SPDT 15A 12VDC Oil Level Sensor (See <b>NOTE 2.</b> )                                       |
| 14   | 810-2243   | Spring, Relay Retaining  |
| 15   | 108-1094   | Plate, Ignition Module   |
| 16   | 824-2090   | Cover, Ignition Module   |
| 17   | 824-2091   | Cover, Ignition Module CE  |
| 18   | 220-7085   | Cover, Ignition Module Australia   |
| 19   | 108-1544   | Plate, Ignition Module Australia   |
| 20   | 807-4812   | Relay, 7-second Time Delay 120V ( <i>U.S., Canadian and Mexico units</i> )                         |
|      | 807-4934   | Relay, 7-second Time Delay 220V, 230V, 240V and 250V units ( <i>International units</i> )          |
| 21   | 106-0531SP | Fuse Assembly, Inline ( <i>not used on all models</i> )  |
| *    | 807-2659   | Switch, Momentary ( <i>Control Power Reset, only used in far left component box</i> )              |
| *    | 807-4403   | Speaker SMT  |
| 22   | 108-1260   | Wire Assembly, Ignition Module Domestic and Non-CE export, except Australia.                       |
|      | 108-2353   | Wire Assembly, Ignition Module CE  |
| 23   | 806-4973   | Interface Board – Australia Only   |
| 24   | 807-1683   | Relay, 12VDC Reset Switch  |

\* Not illustrated.

√ Recommended parts.

† For Full-vat units, use one 807-3366 Dual Spark Ignition Module (see NOTE 1).

† For Dual-vat units, use two 807-3365 Single Spark Ignition Modules (see NOTE 1).

**NOTE 1:** Domestic U.S. and Non-CE Export except Australia units use two different modules depending upon the configuration of the frypot. Full-Vat units use one 807-3366 Dual-Spark Ignition Module while Dual-Vat units use two 807-3365 Single-Spark Ignition Modules. Also, in full-vat units, only two latch relays (Item 12) are used, located in the sockets on the right side of the interface board. These relays are located in the bottom sockets of the interface board and control the heating circuit.

**NOTE 2:** The relays in the top sockets control the oil level sensors.

### 2.5.3 Transformer Boxes

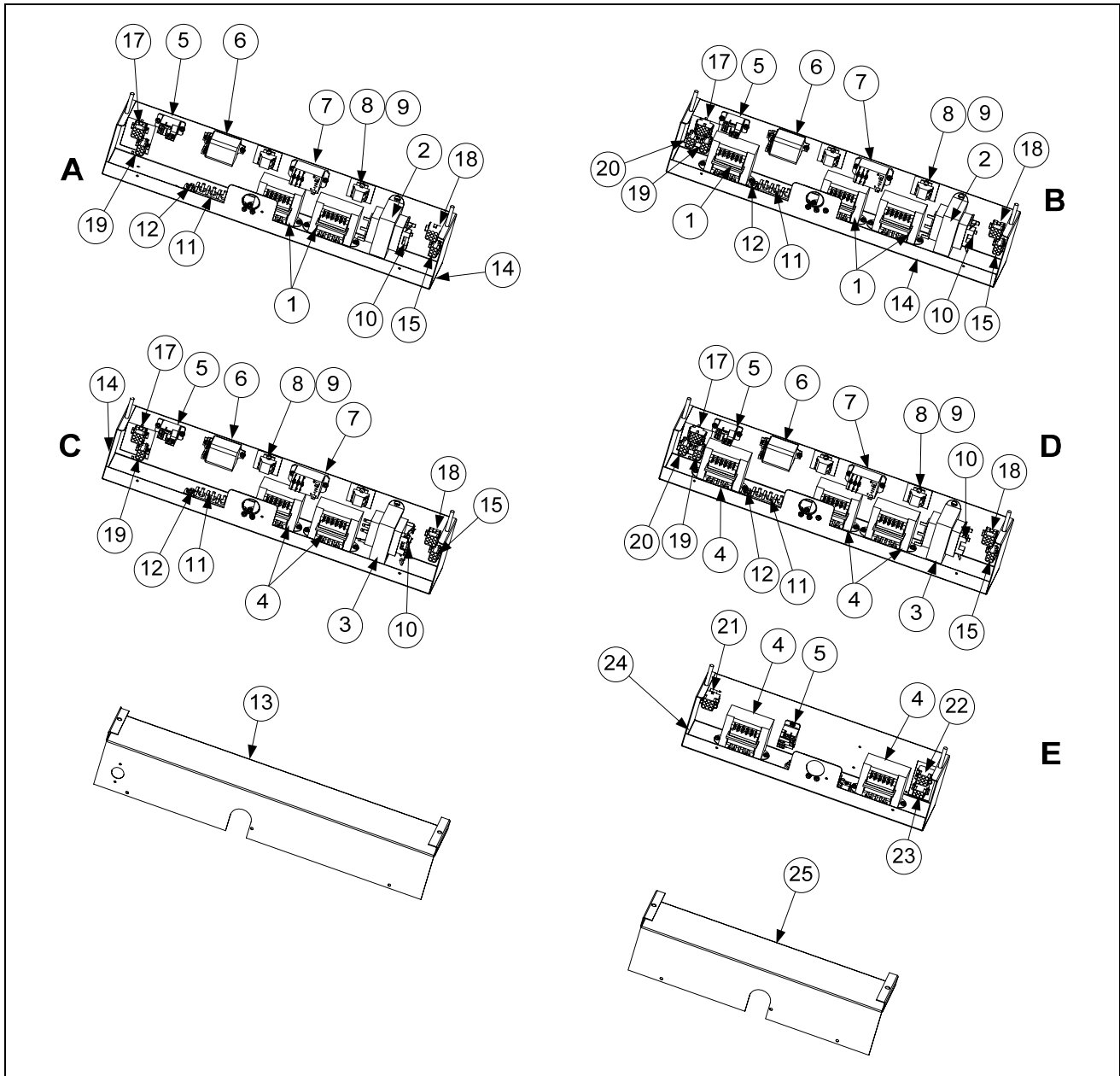

| ITEM | PART #     | COMPONENT   |
|------|------------|---|
|      |            | Box Assembly, Transformer   |
| A    | 106-8135   | GL230 and 430 (430 has added cordset 108-0871)  |
| B    | 106-8122SP | GL330   |
| C    | 106-9734   | GL230 and 430 CE Export (430 has added cordset 108-0871) (106-9750 430 CE Export with 108-0871) |
| D    | 106-9710   | GL330 CE Export   |
| E    | 108-1423   | GL 430 CE Export  |
| √ 1  | 807-2176   | Transformer, 100-120V V/F Dual Voltage  |
| √ 2  | 807-2181   | Transformer, 100-120V/24V 62VA Filter and MIB   |
| √ 3  | 807-2180   | Transformer, 100-120VV/24V 50VA Filter and MIB  |
| 4    | 807-1999   | Transformer, V&F Dual Voltage 208/222/230/240V  |

√ Recommended parts.

### 2.5.3 Transformer Boxes cont.

| ITEM | PART #   | COMPONENT   |
|------|----------|---|
| √ 5  | 807-1683 | Relay, Hood 12V DC  |
| √ 6  | 807-4346 | Relay, DPDT 20A 120VAC (Control Reset Button) <i>(used for control power reset in domestic units)</i> |
| √    | 807-4770 | Relay, DPDT 20A 240V <i>(used for control power reset in international units)</i>                     |
| √ 7  | 807-4482 | Relay, Filter 30A 24VDC DPDT  |
| 8    | 816-0217 | Insulation, Terminal Block Paper  |
| 9    | 810-1164 | Block, One-Piece Screwless Terminal   |
| √ 10 | 807-1597 | Fuse, 3amp Slo-Blow   |
| 11   | 807-1973 | Terminal, Post  |
| 12   | 807-0070 | Terminal, Ground Lug  |
| 13   | 220-3191 | Cover, Large Transformer Box  |
| 14   | 823-6324 | Box, Large Transformer/Filter   |
| 15   | 106-8133 | Cable Assembly, Transformer Box Line GL230, 330, 430, 230 and 330 CE Export and 430 CE Export         |
| 16   | 106-8168 | Cable Assembly, Transformer Box Line GL230 CE Export  |
| 17   | 106-8170 | Cable Assembly, Transformer Box Filter Pump GL230, 330, 230 and 330 CE Export                         |
| 18   | 108-0994 | Cable Assembly, Transformer Box #1 GL230,330, 230 and 330 CE Export                                   |
| 19   | 108-0995 | Cable Assembly, Transformer Box #2 GL230, 330, 230 and 330 CE Export                                  |
| 20   | 108-0996 | Cable Assembly, Transformer Box #3 GL330 and 330 CE Export  |
| 21   | 806-8706 | Plug Assembly, LT #252  |
| 22   | 806-8707 | Plug Assembly, RT #252  |
| 23   | 106-6996 | Harness Assembly, Cord set Female McD   |
| 24   | 823-7400 | Box, Transformer/Filter GL30 4-Battery  |
| 25   | 220-6514 | Cover, GL30 4-Battery Transformer Box   |
| *    | WIR 0100 | Wire Assembly, GL 430 McD Double (used in Item E)   |
| *    | WIR 0623 | Wire Assembly, GL230/430 Hood Relay (used in Item A, B, C and D)                                      |
| *    | WIR 0798 | Wire Assembly, GL330 Transformer/Filter Box (used in Item B, C and D)                                 |
| *    | WIR 0799 | Wire Assembly, GL230/430 Transformer/Filter Box (used in Item A)                                      |

\* Not illustrated

√ Recommended parts.

### 2.5.4 Computers and Associated Components

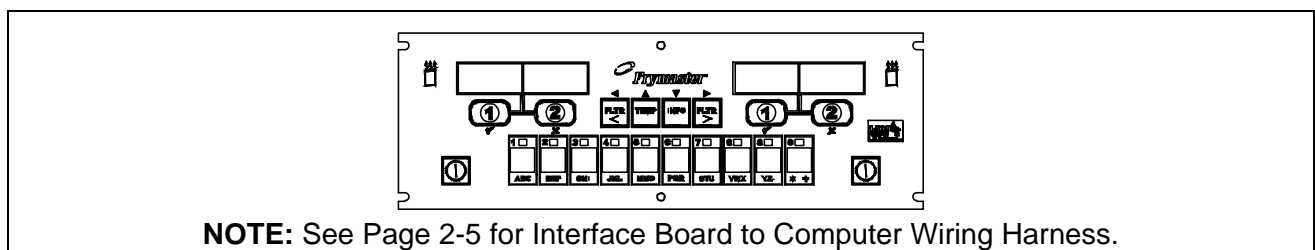

| ITEM | PART #   | COMPONENT  |
|------|----------|--|
|      |          | Computer, McDonald's M3000 Gas Fryer SMT                                       |
| √    | 108-1284 | Non-CE M3000 <i>(For use in US, Canada, Mexico and other non-CE countries)</i> |
| √    | 108-1282 | CE M3000 <i>(For use in European CE countries)</i>                             |
| √    | 108-2969 | M3000 <i>(For use in Russia only)</i>  |
| √    | 108-1290 | M3000 <i>(Australia Only)</i>  |
| *    | 807-4403 | M3000 Speaker SMT  |

\* Not illustrated.

√ Recommended parts.

## 2.6 Wiring

### 2.6.1 Main Wiring Harnesses

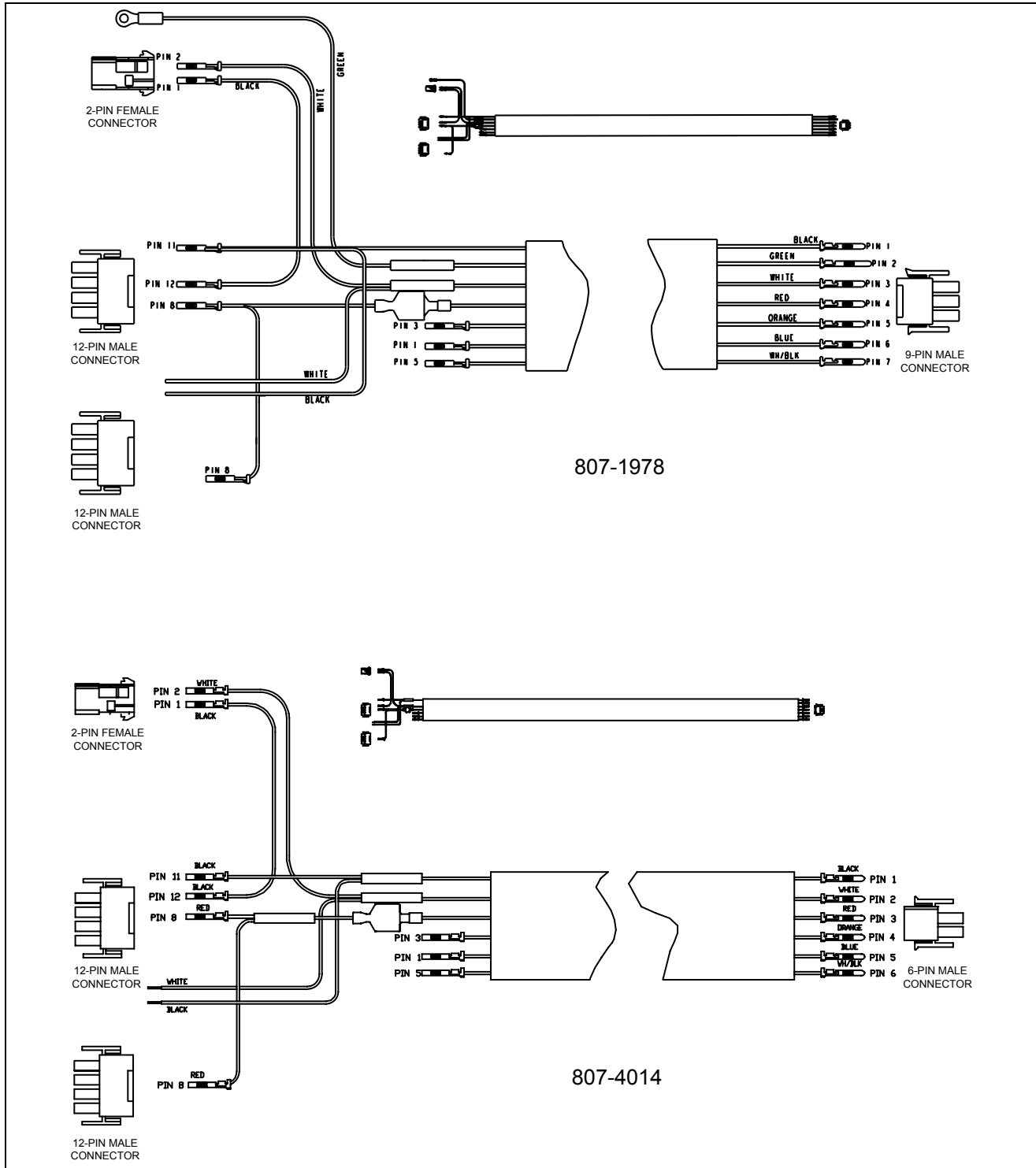

| ITEM | PART #   | COMPONENT   |
|------|----------|---|
|      | 807-1978 | U.S. and Non-CE Export Main Wiring Harness 50/52  |
|      | 807-4014 | U.S. and Non-CE Export Main Wiring Harness 350/52 |
|      | 807-2168 | CE Main Wiring Harness (not shown)                |

## 2.6.2 Miscellaneous Wiring

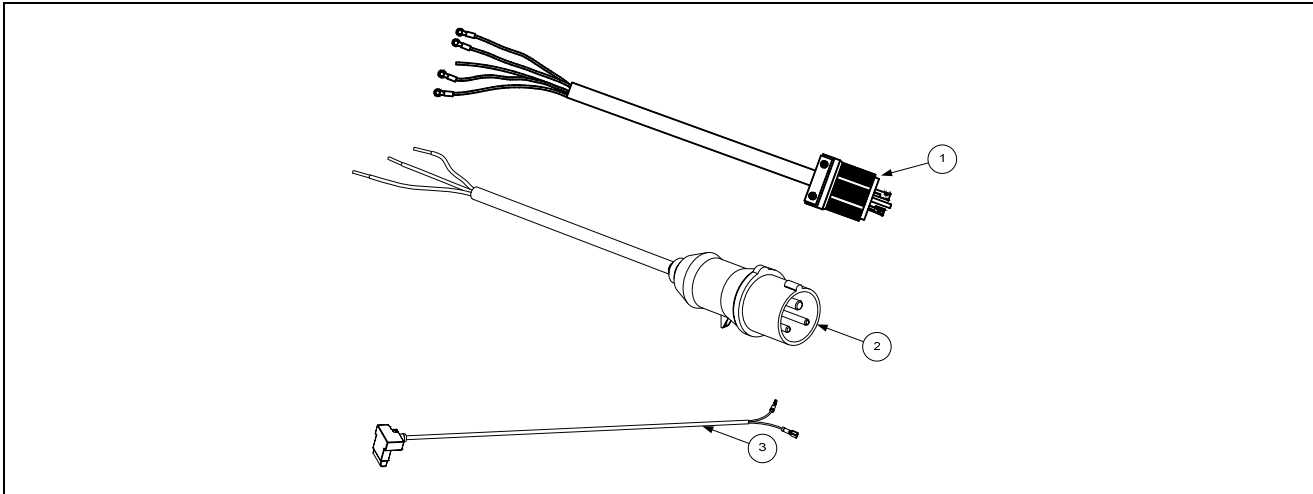

| ITEM | PART #     | COMPONENT   |
|------|------------|---|
| 1    | 807-4316   | Power Cord, 120V w/Grounding Plug 5 wire (w/Ring Terminals, no Clamp) |
| 2    | 807-4317   | Power Cord, CE  |
|      | 807-5225   | Power Cord, 3-Wire 15A, 250V (Korea)                                  |
| 3    | 806-9678SP | Plug Assembly, CE Gas Valve   |

## 2.6.3 M3000, MIB, AIF and ATO Wiring Harnesses (Refer to wiring diagram on page 1-60.)

| ITEM | PART #     | COMPONENT  |
|------|------------|--|
| *    | 807-4546   | Computer Communication (used from Computer to Computer)  |
| *    | 807-4547   | AIF Communication/Power (used from AIF to AIF and AIF to ATO)  |
| *    | 807-4850   | Communication/Power (used from MIB to AIF)   |
| *    | 807-4562   | MIB Power/Blue LED/Pan Sw (used from Transformer and Fltr Rly to MIB to Blue LED and Pan Sw)                         |
| *    | 807-4655   | FV/DV Harness RTD Extension 20" (used from RTD to ATO Board)   |
| *    | 807-4845   | FV/DV Harness RTD Extension 28" (used from RTD to ATO Board)   |
| *    | 826-2569   | FV/DV ATO/RTD Probe Kit  |
| *    | 807-4621   | FV/DV Harness RTD Short (used from RTD to ATO Board)   |
| *    | 807-4771   | ATO Power (used from Transformer to ATO Board)   |
| *    | 807-4555   | ATO Yellow LED (used from ATO Board to Yellow LED)   |
| *    | 807-4573   | Computer Locator Wire (used from Computer to Interface Board) See wiring diagram 805-1725 for locator pin positions. |
| *    | 807-4552   | Communications Terminator (used on Computer pin J6 and ATO board pin J10 to terminate network)                       |
| *    | 106-8977   | Long Top-off Power (used between Transformer Box to ATO Box) Domestic  |
| *    | 108-1589   | Long Top-off Power (used between Transformer Box to ATO Box) CE and Export   |
| *    | 106-9544   | ATO Power to Secondary ATO box (4 and 5 battery only)  |
| *    | 807-4671   | Harness, LOV™ RTI-MIB connector  |
| √ *  | 807-4660PK | SMT Pin Service Repair Kit   |
| √ *  | 230-2345   | SMT Pin Extractor  |

\* Not illustrated.

√ Recommended parts.

See page 1-27, 1-32, 1-39 and 1-50 for Pin Positions.

## 2.7 Frypots and Associated Components

### 2.7.1 Full-Vat Frypot Components

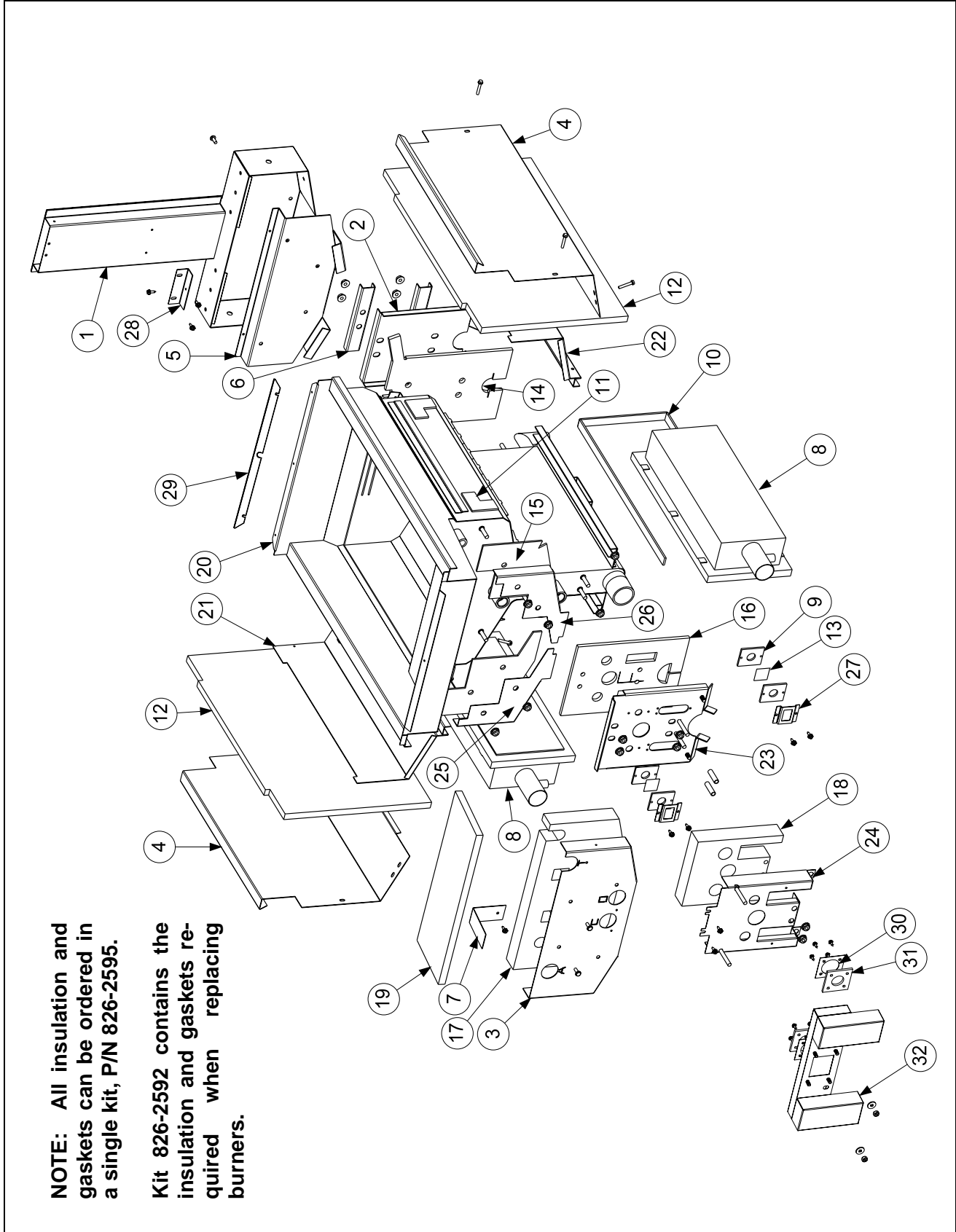

**NOTE:** All insulation and gaskets can be ordered in a single kit, P/N 826-2595.

Kit 826-2592 contains the insulation and gaskets required when replacing burners.

## 2.7.1 Full-Vat Frypot Components cont.

| ITEM | PART #     | COMPONENT  |
|------|------------|--|
|      | 108-0858SP | Frypot Assembly Full-Vat LOV™ HE (NAT/PRO)   |
|      | 826-2595   | Insulation Kit, Complete Full-Vat  |
|      | 826-2592   | Insulation Kit, Burner Full-Vat  |
| 1    | 108-0925   | Flue Assembly, Full-Vat  |
| 2    | 220-6470   | Back, Lower Full-Vat Combustion Chamber  |
| 3    | 220-6529   | Retainer, Full-Vat Upper Insulation  |
| 4    | 220-6664   | Retainer, Outer Frypot   |
| 5    | 230-6960   | Plate, FV Collector Mounting   |
| 6    | 220-2851   | Brace, FV Rear Insulation  |
| 7    | 220-2920   | Brace, Foam Deck Insulation  |
| √ 8  | 810-3435   | Burner, Universal Replacement LOV™   |
| 9    | 812-0356   | Insulation, Burner Sight Glass   |
| 10   | 816-0900   | Insulation, Burner   |
| 11   | 812-0706   | Insulation, Upper Burner Rail  |
| 12   | 812-1029   | Insulation, Combustion Chamber Side  |
| 13   | 814-0048SP | Glass, Burner Sight  |
| 14   | 816-0837   | Insulation, FV Rear Lower  |
| 15   | 816-0731   | Insulation, FV LH/RH Front Seal  |
| 16   | 816-0732   | Insulation, FV Lower Inner Front   |
| 17   | 816-0733   | Insulation, FV Front Upper   |
| 18   | 816-0839   | Insulation, FV Outer Front   |
| 19   | 816-0746   | Insulation, Foam Deck  |
| 20   | 823-7283   | Frypot, FV LOV™ 30 439 SS  |
| 21   | 823-8193   | Retainer, FV LH Upper Burner   |
| 22   | 823-8194   | Retainer, FV RH Upper Burner   |
| 23   | 823-7279   | Retainer, FV Front Insulation  |
| 24   | 823-7415   | Retainer, FV Outer Front   |
| 25   | 824-2164   | Front Upper Seal Weldment, FV LH   |
| 26   | 824-2165   | Front Upper Seal Weldment, FV RH   |
| 27   | 900-1031   | Retainer, Burner Sight Glass   |
| 28   | 930-0818   | Bracket, Flue to Pot   |
| 29   | 900-4253   | Strip, Fluecap Retainer  |
| 30   | 900-1049   | Retainer, Plenum Gasket  |
| 31   | 816-0057   | Gasket, Plenum   |
| 32   | 823-6660   | Plenum, Full-Vat LOV™ ( <i>use 108-1533 for CE units</i> ) ( <i>use 108-2553 for Export Non-CE units</i> ) |
| *    | 816-0059   | Gasket, Ignitor  |
| *    | 910-2474   | Pot-to-Pot Gap Clip  |

\* Not illustrated.

√ Recommended parts.

## 2.7.2 Dual-Vat Frypot Components

**NOTE:** All insulation and gaskets can be ordered in a single kit, P/N 826-2596.

Kit 826-2593 contains the insulation and gaskets required when replacing burners.

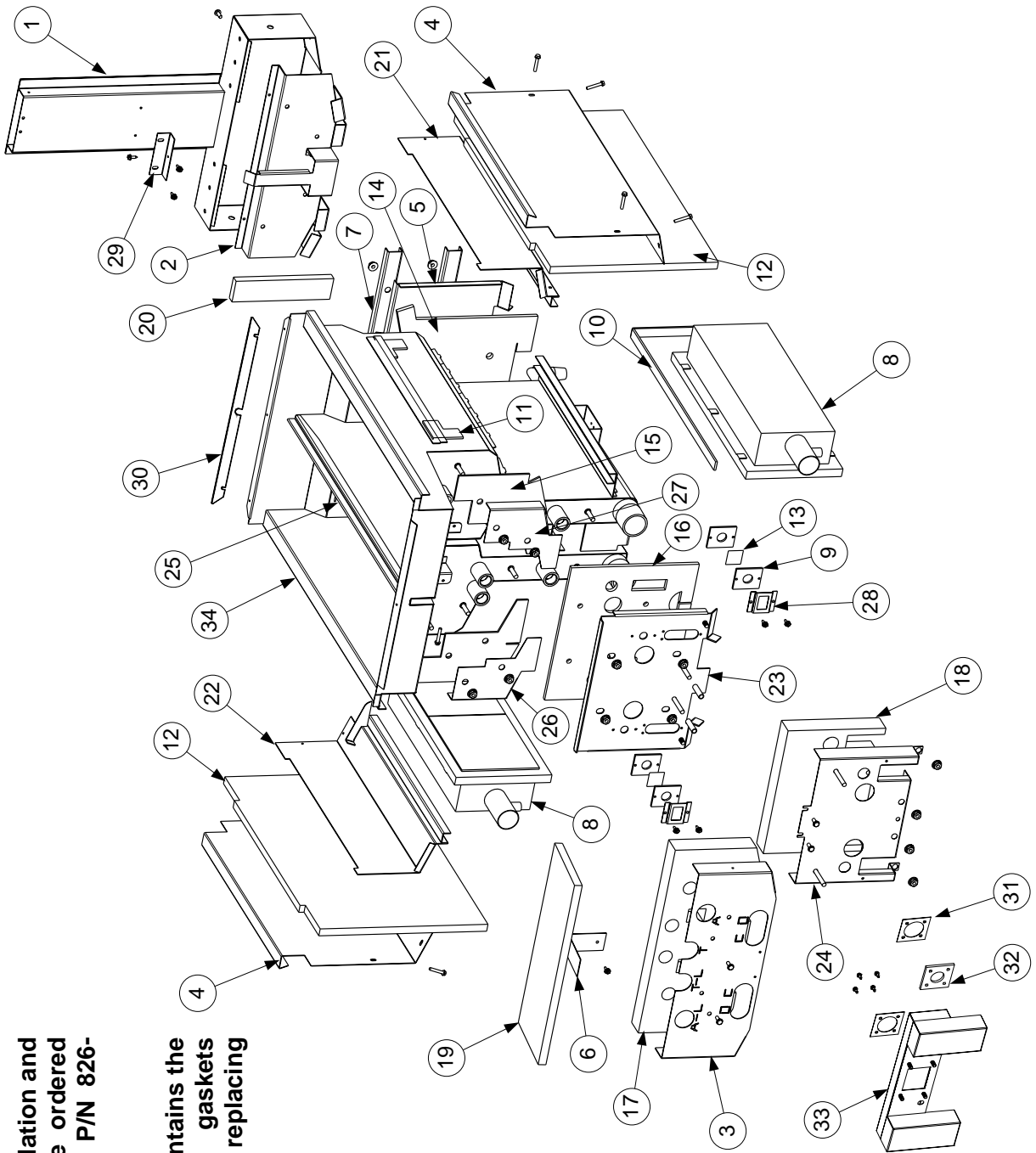

## 2.7.2 Dual-Vat Frypot Components cont.

| ITEM | PART #     | COMPONENT  |
|------|------------|--|
| *    | 108-0860SP | Frypot Assembly Dual-Vat w/RF HE (NAT/PRO)   |
| *    | 826-2596   | Insulation Kit, Complete Dual-Vat  |
| *    | 826-2593   | Insulation Kit, Burner Dual-Vat  |
| 1    | 108-0926   | Flue Assembly, Dual-Vat  |
| 2    | 106-7960   | Plate Assembly, Dual-Vat Collector   |
| 3    | 220-6530   | Retainer, Dual-Vat Upper Insulation  |
| 4    | 220-6665   | Retainer, Dual-Vat Outer Frypot  |
| 5    | 220-6180   | Back, Dual-Vat Lower Combustion Chamber  |
| 6    | 220-2920   | Brace, Foam Deck Insulation  |
| 7    | 220-2972   | Brace, Dual-Vat Rear Insulation  |
| √ 8  | 810-3435   | Burner, Universal Replacement  |
| 9    | 812-0356   | Insulation, Burner Sight Glass   |
| 10   | 816-0900   | Insulation, Burner   |
| 11   | 812-0706   | Insulation, Upper Burner Rail  |
| 12   | 812-1029   | Insulation, Combustion Chamber Side  |
| 13   | 814-0048SP | Glass, Burner Sight  |
| 14   | 816-0838   | Insulation, Dual-Vat Rear Lower  |
| 15   | 816-0741   | Insulation, Dual-Vat LH/RH Front Seal  |
| 16   | 816-0742   | Insulation, Dual-Vat Lower Inner Front   |
| 17   | 816-0743   | Insulation, Dual-Vat Front Upper   |
| 18   | 816-0840   | Insulation, Dual-Vat Outer Front   |
| 19   | 816-0746   | Insulation, Foam Deck  |
| 20   | 812-0688   | Insulation, Flue Collection  |
| 21   | 823-8196   | Retainer, Dual-Vat RH Upper Burner   |
| 22   | 823-8195   | Retainer, Dual-Vat LH Upper Burner   |
| 23   | 823-7416   | Retainer, Dual-Vat Front Insulation  |
| 24   | 823-7417   | Retainer, Dual-Vat Outer Front   |
| 25   | 824-1796   | Riser W/A Dual-Vat Pot   |
| 26   | 824-2166   | Dual-Vat LH Upper W/A Seal   |
| 27   | 824-2167   | Dual-Vat RH Upper W/A Seal   |
| 28   | 900-1031   | Retainer, Sight Glass  |
| 29   | 930-0818   | Bracket, Flue to Pot   |
| 30   | 900-4253   | Strip, Fluecap Retainer  |
| 31   | 900-1049   | Retainer, Plenum Gasket  |
| 32   | 816-0057   | Gasket, Plenum   |
| *    | 816-0059   | Gasket, Ignitor  |
| 33   | 823-6659   | Plenum, Dual-Vat LOV™ ( <i>use 108-1534 for CE units</i> ) ( <i>use 108-2554 for Export Non-CE units</i> ) |
| 34   | 823-7288   | Frypot, Dual-Vat LOV™ 30 439 SS  |
| *    | 910-2474   | Pot-to-Pot Gap Clip  |

\* Not illustrated.

√ Recommended parts.

## 2.7.3 Frypot Assemblies and Associated Parts

### 2.7.3.1 Frypots with Linear Actuators

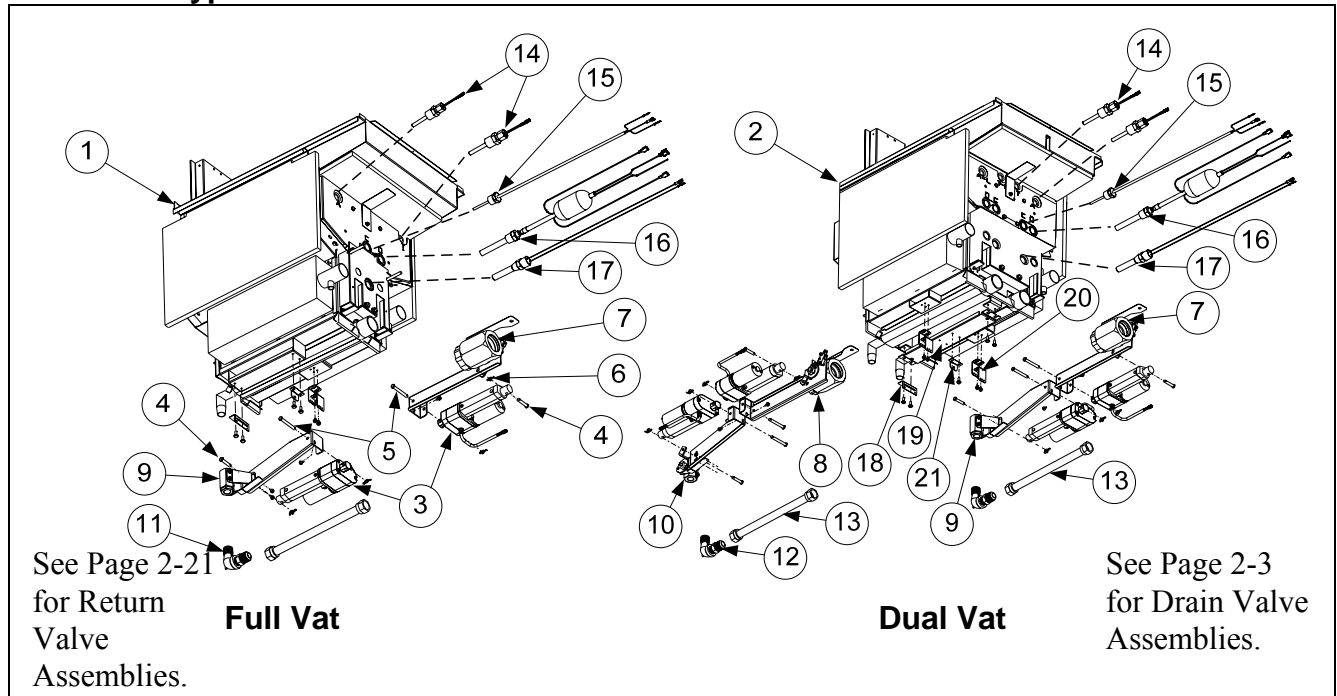

| ITEM | PART #     | COMPONENT   |
|------|------------|---|
| 1    | 108-0858SP | Frypot Assembly, Full-Vat LOV™ Natural/Propane                          |
| 2    | 108-0860SP | Frypot Assembly, Dual-Vat LOV™ Natural/Propane                          |
| √ 3  | 826-2587   | Actuator, Linear AIF 24VDC Kit (includes 810-1776)                      |
| √ 4  | 809-1012   | Pin, Clevis, ¼ x 1¼   |
| √ 5  | 809-1036   | Pin, Clevis, ¼ x 2  |
| √ 6  | 810-1776   | Cotter Pin, Toaster Ring  |
| 7    | 108-0748   | Valve, Drain Assy. LOV™ AIF FV or DV Right viewed from front of frypot. |
| 8    | 108-0747   | Valve, Drain Assy LOV™ AIF DV Left as viewed from front of frypot.      |
| 9    | 108-0750   | Valve, Return Assy LOV™ AIF FV or DV Right viewed from front of frypot. |
| 10   | 108-0749   | Valve, Return Assy LOV™ AIF DV Left as viewed from front of frypot.     |
| 11   | 813-0165   | Elbow, Street ½" x ½" NPT 90° BM  |
| 12   | 810-1668   | Adaptor, Male ⅝" OD x ½"  |
| 13   | 810-1055   | Flexline, ⅝" OD x 11.50" Long   |
| √ 14 | 826-2706   | Probe, RTD AIF/ATO Kit  |
| √ 15 | 807-4817   | Probe, Temperature Cooking  |
| √ 16 | 807-4815   | Sensor Assy, Oil 120V   |
|      | 807-4947   | Sensor Assy, Oil 220V and 230V <i>International</i>                     |
|      | 807-4942   | Sensor Assy, Oil 240V and 250V <i>International</i>                     |
| √ 17 | 826-1177   | Thermostat Assembly, HE High-Limit 425°F/218°C Standard                 |
| 18   | 220-6472   | Bracket, Rear AIF Mounting  |
| 19   | 220-3183   | Brace, DV AIF Support   |
| 20   | 220-6666   | Bracket, Actuator Support   |
| 21   | 220-5299   | Bracket, Front AIF Mounting   |

√ Recommended parts.

### 2.7.3.2 Frypots with Rotary Actuators

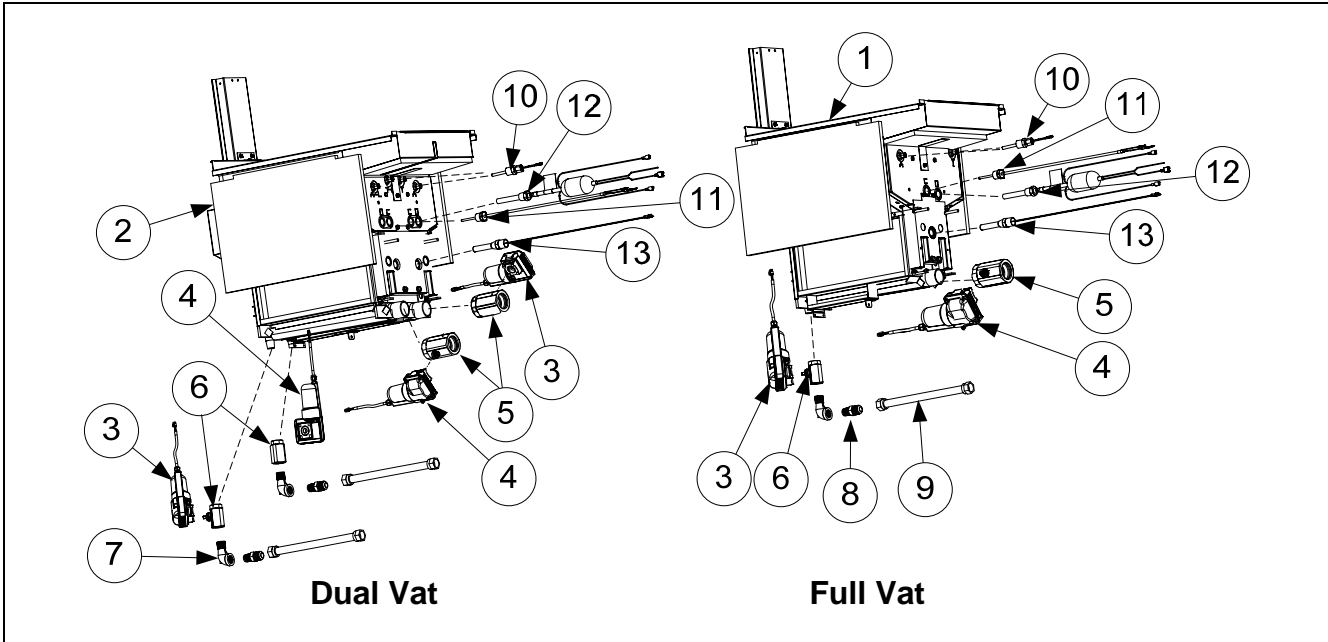

| ITEM | PART #     | COMPONENT   |
|------|------------|---|
| 1    | 108-1752SP | Frypot Assembly, Full-Vat LOV™ Natural/Propane          |
| 2    | 108-1753SP | Frypot Assembly, Dual-Vat LOV™ Natural/Propane          |
| √ 3  | 807-4961   | Actuator, Rotary 24VDC (#1)                             |
| √ 4  | 807-4962   | Actuator, Rotary 24VDC (#2)                             |
| √ 5  | 810-3755   | Valve, 1/4 Drain Rotary Actuator LOV™                   |
| √ 6  | 810-3754   | Valve, 1/2 NPT Return Rotary Actuator LOV™              |
| 7    | 813-0165   | Elbow, Street 1/2" x 1/2" NPT 90° BM                    |
| 8    | 810-1668   | Adaptor, Male 5/8" OD x 1/2"                            |
| 9    | 810-1055   | Flexline, 5/8" OD x 11.50" Long                         |
| √ 10 | 826-2706   | Probe, RTD AIF/ATO Kit                                  |
| √ 11 | 807-4817   | Probe, Temperature Cooking                              |
| √ 12 | 807-4815   | Sensor Assy, Oil 120V                                   |
|      | 807-4947   | Sensor Assy, Oil 220V and 230V <i>International</i>     |
|      | 807-4942   | Sensor Assy, Oil 240V and 250V <i>International</i>     |
| √ 13 | 826-1177   | Thermostat Assembly, HE High-Limit 425°F/218°C Standard |

√ Recommended parts.

## 2.8 Oil Return Manifolds

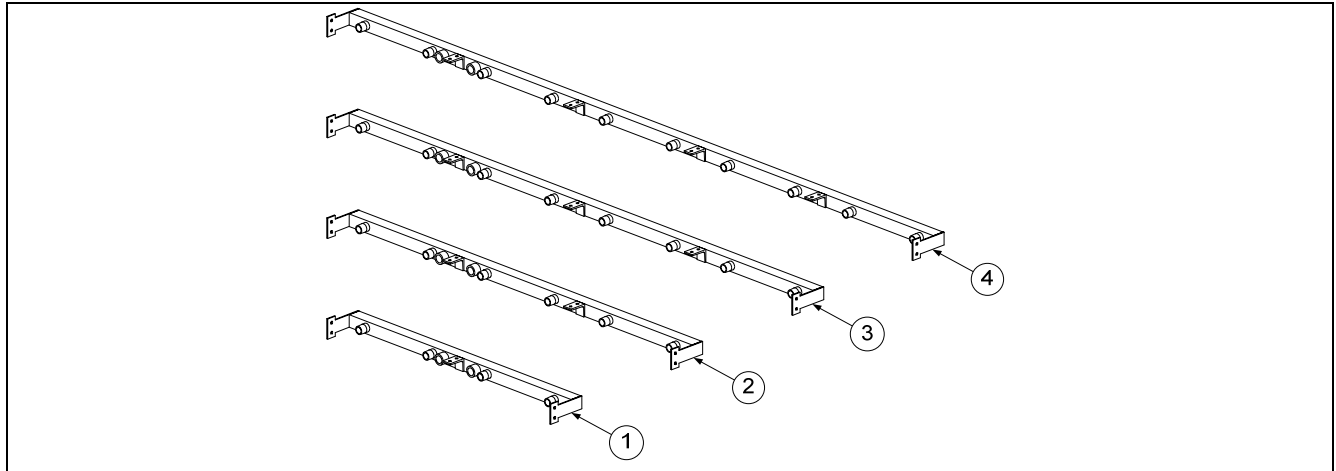

| ITEM | PART #   | COMPONENT                     |
|------|----------|-------------------------------|
| 1    | 810-3275 | Manifold, Two-Station Fryer   |
| 2    | 810-3245 | Manifold, Three-Station Fryer |
| 3    | 810-3368 | Manifold, Four-Station Fryer  |
| *    | 813-0907 | Cap, 15/16-inch Valve         |

\* Not illustrated

## 2.9 Return Valves and Associated Parts

### 2.9.1 Return Valves and Associated Parts (Linear Actuators)

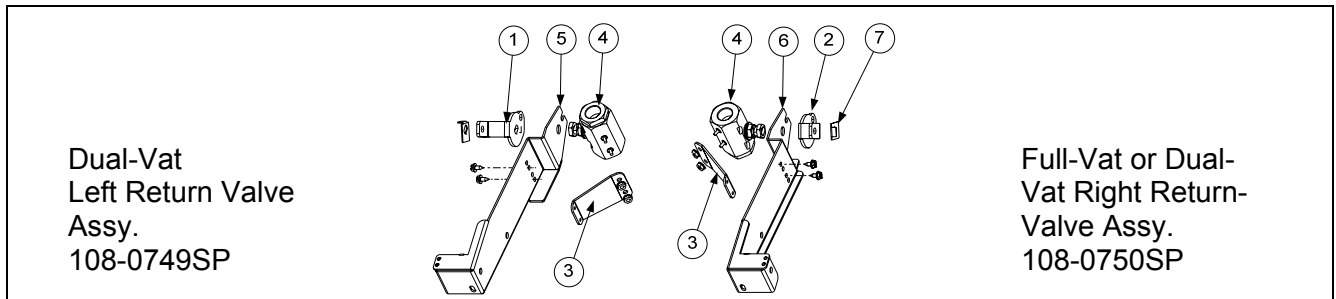

| ITEM | PART #   | COMPONENT                                    |
|------|----------|--|
| 1    | 231-6295 | Handle, Return Valve Gas LOV™ DV Left        |
| 2    | 232-6295 | Handle, Return Valve Gas LOV™ FV or DV Right |
| 3    | 230-6011 | Brace, Gas Return Actuator Bracket           |
| 4    | 810-2201 | Valve, 1/2-inch Ball                         |
| 5    | 823-7273 | Mount, Gas Return Actuator LH                |
| 6    | 823-7274 | Mount, Gas Return Actuator RH                |
| 7    | 900-2935 | Retainer, Nut Oil Return Valve               |

### 2.9.2 Return Valve (Rotary Actuators)

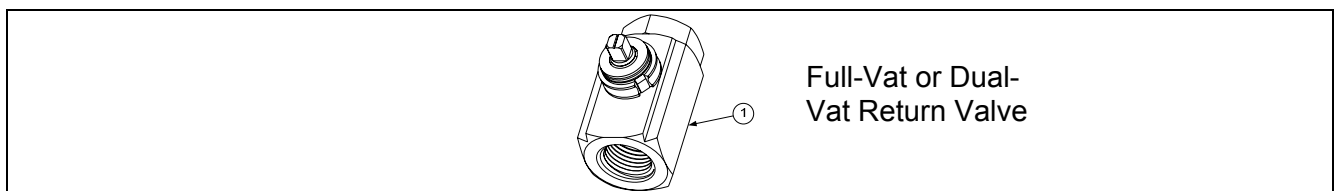

| ITEM | PART #   | COMPONENT                           |
|------|----------|-------------------------------------|
| 1    | 810-3754 | Valve, 1/2-inch NPT Rotary Actuator |

## 2.10 Gas Supply and Combustion System Components

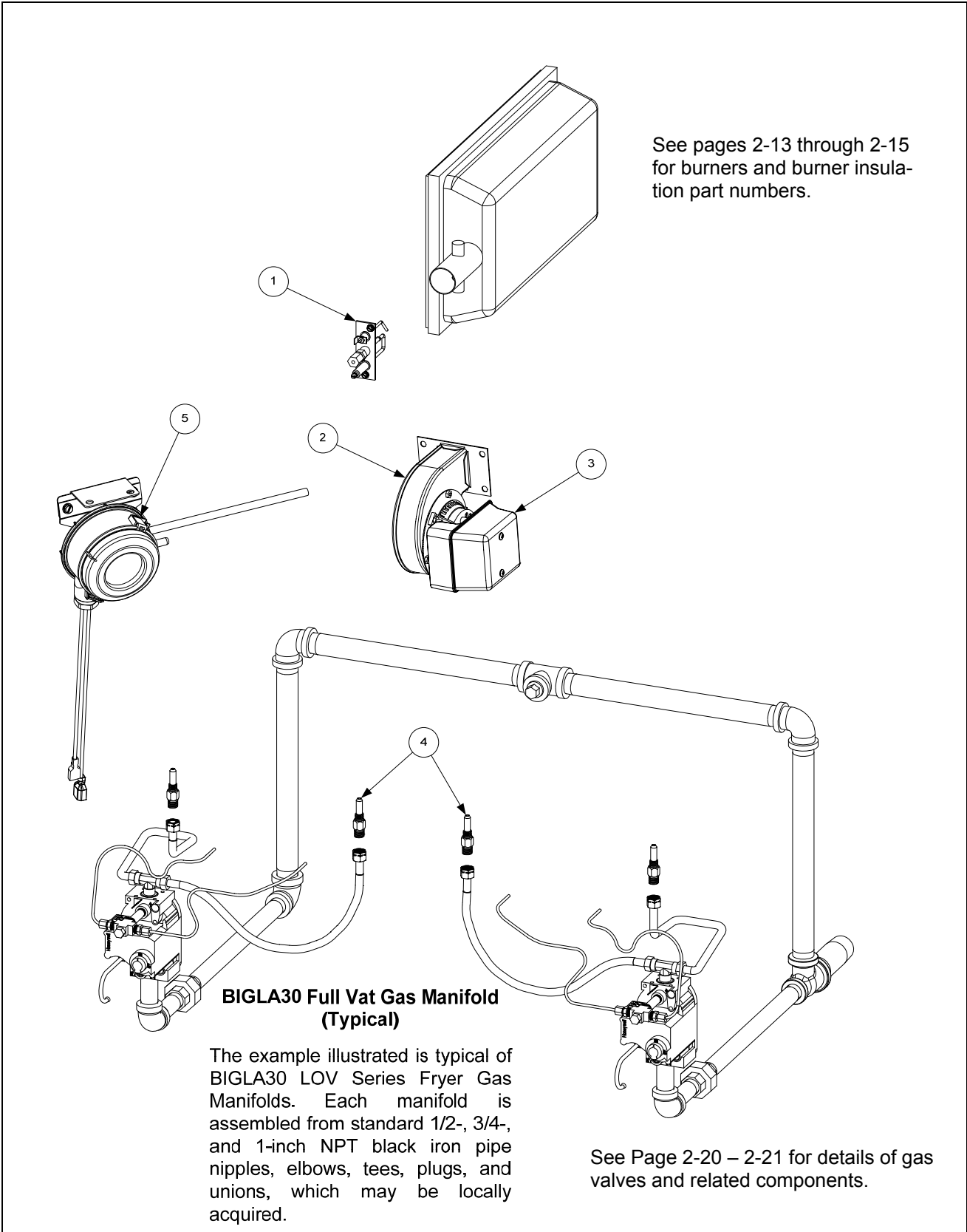

## 2.10 Gas Supply and Combustion System Components cont.

| ITEM | PART #     | COMPONENT  |
|------|------------|--|
| √ 1  |            | Ignitor  |
|      | 826-0981   | Natural Gas (G20, G25) (includes gasket 816-0059, which may be ordered separately) |
|      | 826-2994   | Propane (G30, G31) (includes gasket 816-0059, which may be ordered separately)     |
| √ 2  |            | Blower Assembly, Combustion Air (includes harness and Item 3)                      |
|      | 106-2997SP | 115V 50/60 Hz (Right)  |
|      | 108-3307   | 220V 60 Hz (Right)   |
|      | 106-2998SP | 208-240V 50/60 Hz (Right) Non-CE International                                     |
|      | 106-3001SP | 230V 50/60 Hz CE (Right) CE (Wide Body)  |
| 3    | 816-0554   | Cover, Blower Motor (component of all blowers listed above)                        |
| *    | 806-8806SP | Harness Assembly, Blower Motor (component of all blowers listed above)             |
| 4    |            | Orifice, Burner  |
|      |            | <b>**For fryers manufactured OCT 2010 and after.</b>                               |
|      |            | <b>NPT Threads</b>   |
|      | 810-3977   | 1.88mm 75% Butane/25% Butane (Standard Elevation)                                  |
| **   | 810-3865   | 1.95mm Propane/Butane (G30, G31) Australia Only                                    |
| **   | 810-3860   | 2.05 mm Propane/Butane (G30, G31) (0-4999 Ft, 0-1524 M)                            |
| **   | 810-3863   | 2.10 mm Propane/Butane (G30, G31) (5000-6999 Ft, 1525-2133 M)                      |
| **   | 810-3867   | 2.84mm Natural Gas (G20, G25) Australia Only DV                                    |
| **   | 810-3866   | 2.92mm Natural Gas (G20, G25) Australia Only FV                                    |
| **   | 810-3864   | 3.18 mm Natural Gas (G20, G25) (0-4999 Ft, 0-1524 M) CE                            |
| **   | 810-3861   | 3.26 mm Natural Gas (G20, G25) (0-4999 Ft, 0-1524 M)                               |
| **   | 810-3862   | 3.40 mm Natural Gas (G20, G25) (5000-6999 Ft, 1525-2133 M)                         |
|      |            | <b>† For fryers manufactured prior to OCT 2010</b>                                 |
| †    | 812-1138   | 1.85 mm Propane/Butane (G30, G31) (0-4999 Ft, 0-1524 M) (CE)                       |
| †    | 812-1137   | 1.95mm Propane/Butane (G30, G31) Australia Only                                    |
| †    | 810-0416   | 2.05 mm Propane/Butane (G30, G31) (0-4999 Ft, 0-1524 M)                            |
| †    | 810-0386   | 2.10 mm Propane/Butane (G30, G31) (5000-6999 Ft, 1525-2133 M)                      |
| †    | 812-1135   | 2.15 mm Propane/Butane (G30, G31) (7000-10,999 Ft, 2134-3352 M)                    |
| †    | 810-3840   | 2.84mm Natural Gas (G20, G25) Australia Only DV                                    |
| †    | 810-3839   | 2.92mm Natural Gas (G20, G25) Australia Only FV                                    |
| †    | 810-3740   | 3.18 mm Natural Gas (G20, G25) (0-4999 Ft, 0-1524 M) CE                            |
| †    | 810-3269   | 3.26 mm Natural Gas (G20, G25) (0-4999 Ft, 0-1524 M)                               |
| †    | 810-0403   | 3.40 mm Natural Gas (G20, G25) (5000-6999 Ft, 1525-2133 M)                         |
| †    | 812-0909   | 3.45 mm Natural Gas (G20, G25) (7000-8999 Ft, 2134-2743 M)                         |
| †    | 812-1133   | 3.50 mm Natural Gas (G20, G25) (9000-10,999 Ft, 2744-3352 M)                       |
| √ 5  | 108-1455SP | Switch, Air Pressure Assembly DV (812-2141 switch alone)                           |
| √    | 108-3346   | Switch, Air Pressure Assembly FV (812-2226 switch alone)                           |

\* Not illustrated.

√ Recommended parts.

## 2.11 Gas Valves and Associated Components

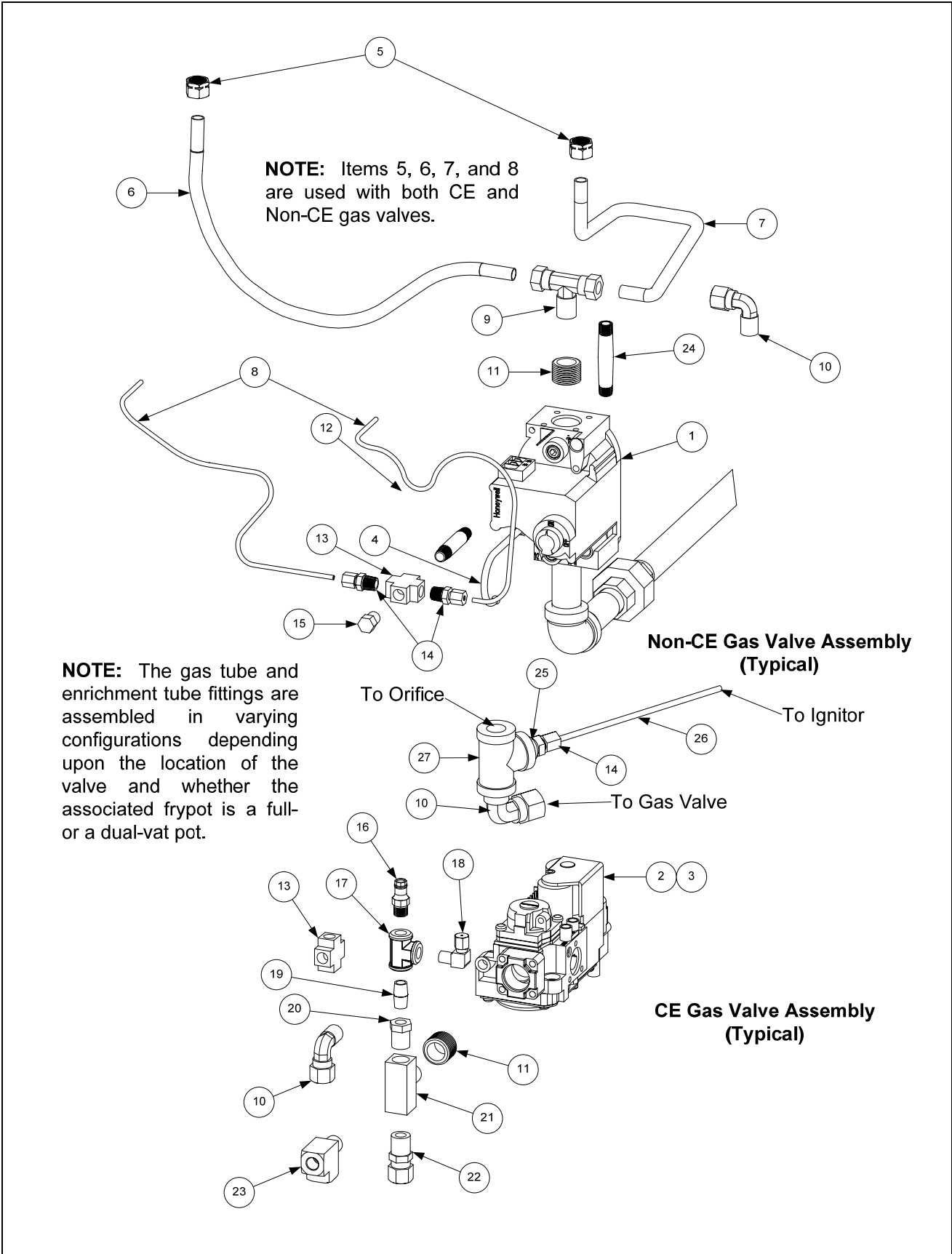

## 2.11 Gas Valves and Associated Components cont.

| ITEM | PART #   | COMPONENT  |
|------|----------|--|
| √ 1  |          | Valve, Non-CE Gas  |
|      | 826-1122 | Natural Gas (G20, G25)   |
|      | 826-1120 | Kit Natural Gas w/ flexlines and hardware                                      |
|      | 826-1123 | Propane Gas (G30, G31)   |
|      | 826-1121 | Kit, Propane Gas w/ flexlines and hardware                                     |
| √ 2  | 810-1715 | Valve, CE Gas (G20, G25, G30, G31)   |
| 3    | 810-1041 | Accessory Kit (contains parts to adapt Item 2 to specific fryer configuration) |
| 4    | 810-0691 | Tube, 1/8-inch Vent  |
| 5    | 810-0494 | Ferrule (Nut), Orifice   |
| 6    | 810-1355 | Gas Line, 3/8-inch OD X 15-inch SS Flexible                                    |
| 7    | 810-1354 | Gas Line, 3/8-inch OD X 12-inch SS Flexible                                    |
|      | 810-1353 | Gas Line, 3/8-inch OD X 9-inch SS Flexible (Used on some split pots)           |
| 8    | 811-0800 | Tube, 1/8-inch OD X 12.5-inch Enrichment (cut and form to fit)                 |
| *    | 810-3807 | Tube, 1/8-inch OD X 6.5-inch Enrichment ( <i>Used after Oct 2010</i> )         |
| 9    | 813-0301 | Tee, 1/4-inch Male NPT to 3/8-inch Tube  |
| 10   | 813-0302 | Elbow, 1/4-inch Male NPT to 3/8-inch Tube 90° (used on DV valve)               |
| 11   | 813-0304 | Bushing, 1/2-inch NPT to 1/4-inch NPT Flush Reducing                           |
| 12   | 813-0405 | Nipple, 1/8-inch NPT X 2-inch  |
| 13   | 813-0378 | Fitting, 1/8-inch NPT Cross  |
| 14   | 813-0340 | Adapter, 1/8-inch NPT to 1/8-inch Tube   |
| 15   | 813-0154 | Plug, 1/8-inch NPT Hex Head Pipe   |
| 16   | 810-1176 | Tap, 1/8-inch NPT Pressure   |
| 17   | 813-0377 | Tee, 1/8-inch NPT Female   |
| 18   | 813-0354 | Elbow, 1/8-inch NPT X 1/8-inch Tube Compression                                |
| 19   | 813-0016 | Nipple, 1/8-inch NPT X Close   |
| 20   | 810-1006 | Bushing, 1/4-inch NPT to 1/8-inch NPT Reducing                                 |
| 21   | 813-0495 | Tee, 1/4-inch Male NPT to Female NPT   |
| 22   | 810-1025 | Connector, 1/4-inch Male NPT to 3/8-inch Tube                                  |
| 23   | 810-1026 | Tee, 1/4-inch Male NPT to Female NPT Street                                    |
| 24   | 813-0700 | Nipple, 1/4-inch NPT x 3-inch  |
| 25   | 810-3147 | Bushing, 3/4-inch OD x 1/2 -inch ID NPT Flush                                  |
| 26   | 810-3807 | Tube, FPGL Gas Enrichment  |
| 27   | 813-0449 | Tee, 1/4 -inch NPT Brass   |

√ Recommended parts.

## 2.12 Filtration System Components

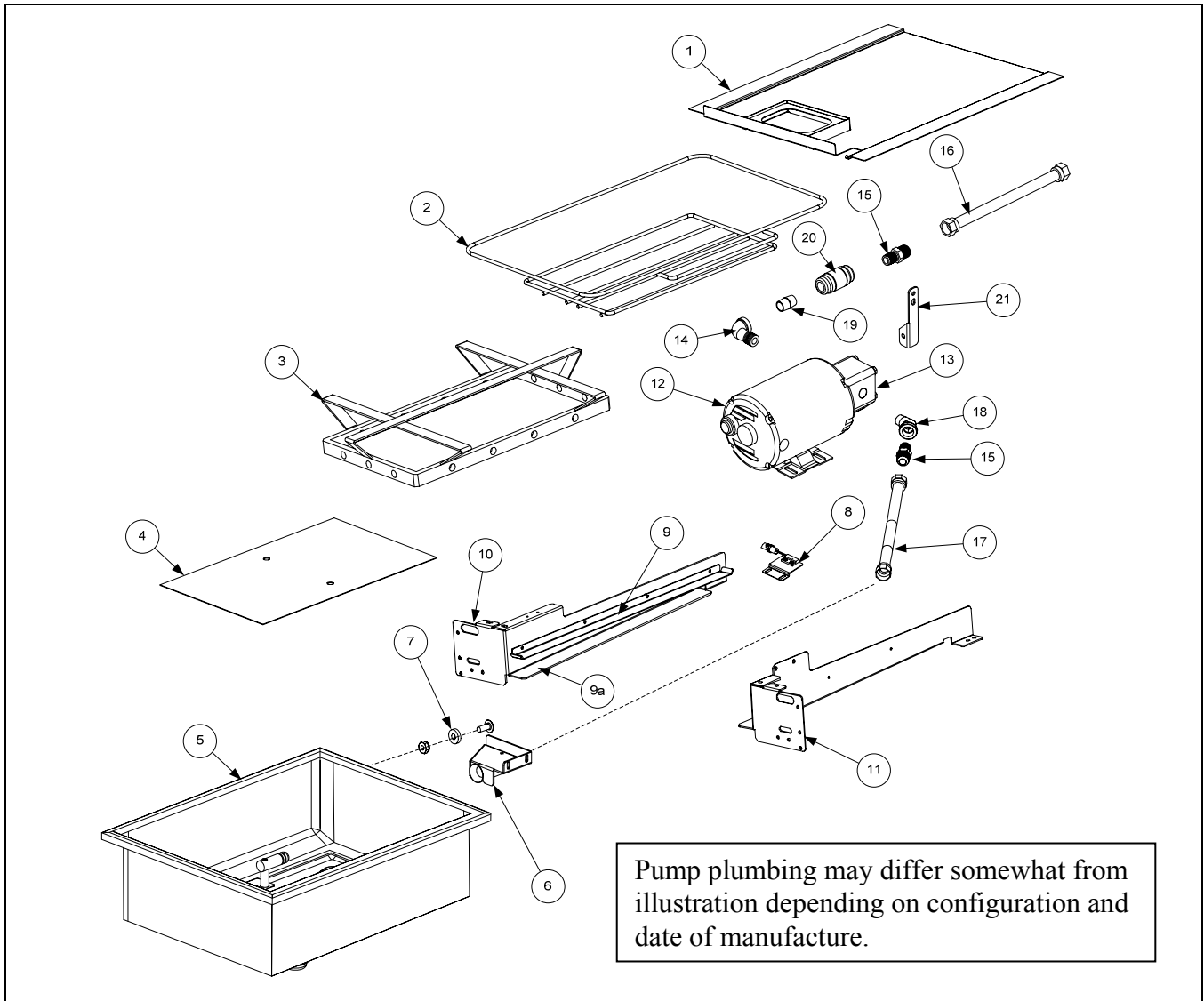

| ITEM | PART #     | COMPONENT   |
|------|------------|---|
| 1    | 823-7602   | Lid, Multi-Vat Fryers, Standard Size Filter Pan                               |
|      | 823-7607   | Lid, Two-Vat Fryer, Half Size Filter Pan                                      |
| 2    | 810-3276   | Crumb Tray, Standard Size Filter Pan 3, 4 and 5 Vat                           |
|      | 810-3288   | Crumb Tray, Two-Vat Fryer, Half Size Filter Pan                               |
| 3    | 810-3268   | Hold-Down Ring for Pad 16.56 x 22.32, Standard Size Pan 3, 4, and 5 Vat       |
|      | 810-3289   | Hold-Down Ring for Pad 11.20 x 19.10, Two-Vat Fryer, Half Size Filter Pan     |
| 4    | 200-2240   | SanaGrid Filter Screen, Standard Size Filter Pan                              |
|      | 220-2901   | SanaGrid Filter Screen, Two-Vat Fryer, Half Size Filter Pan                   |
| 5    | 108-1209   | Pan, One-Piece Filter LOV™ Standard Size <i>(Use 106-9148 for French Pan)</i> |
|      | 106-8211SP | Pan, Two-Vat Fryer, LOV™ Half Size  |
| √ *  | 826-1392   | O-Ring (Pkg. of 5; used with Item 5)  |
| *    | 813-0568   | Plug, 1/8-inch Socket Head Pipe (used with Item 5; two required)              |
| 6    | 823-3879   | Suction Tube Standard LOV™  |
|      | 823-6458   | Suction Tube Two Vat LOV™   |
| 7    | 810-3007   | Magnet, Pull Ring   |

\* Not illustrated. √ Recommended parts

## 2.12 Filtration System Components cont.

| ITEM | PART #     | COMPONENT   |
|------|------------|---|
| 8    | 108-2218   | Assembly, Filter Pan Switch 3, 4 and 5 Battery                          |
|      | 108-0839   | Assembly, Filter Pan Switch 2 Battery                                   |
| √ *  | 106-5876SP | Sensor, Magnet  |
| 9    | 220-3879   | Rail, Filter Pan Retaining Standard                                     |
|      | 231-4821   | Rail, Filter Pan Retaining Two Vat Left (use 232-4822 for Right)        |
| 9a   | 230-4820   | Rail, RH LH Lower Two Vat   |
| 10   | 220-7911   | Support, Left Filter Pan  |
|      | 220-7909   | Support, Left Filter Pan Two Vat LOV™                                   |
| 11   | 220-7912   | Support, Right Filter Pan   |
|      | 220-7910   | Support, Right Filter Pan Two Vat LOV™                                  |
| √ 12 |            | Motor and Gasket Kit  |
|      | 826-1785   | 100V 50/60 Hz   |
|      | 826-1712   | 115V 50/60 Hz   |
|      | 826-1756   | 208V 50/60 Hz   |
|      | 826-1270   | 220-240V 50/60 Hz   |
|      | 826-1755   | 250V 50/60 Hz   |
| √ 13 | 826-1264   | Pump and Gasket Kit, 4 GPM  |
|      | 816-0093   | Gasket, Pump/Motor  |
| *    | 807-11973  | Viking Pump Seal Kit  |
| *    | 809-1020   | Cap Screw, 5/16-inch-18 5.50" NC Hex ( <i>Connects pump to motor.</i> ) |
| 14   | 813-0165   | Elbow, ST ½-inch x ½-inch NPT 90° BM                                    |
| 15   | 810-1668   | Adapter, ⅝-inch to ½-inch NPT Male                                      |
| 16   | 810-1067   | Flexline, 8.5-inch Oil Return   |
| 17   | 810-1057   | Flexline, 13-inch Oil Return  |
| 18   | 813-0342   | Elbow, Street 45° x ½-inch NPT  |
| 19   | 813-0002   | Nipple, ½-inch x Close NPT BM   |
| 20   | 810-0667   | Check Valve ½-inch NPT  |
| 21   | 220-6190   | Brace, Pump Motor   |
| *    | 807-1105   | Heater Strip Assembly, 100-120V 25W 18"                                 |
| *    | 807-1098   | Heater Strip Assembly, 208-250V 25W 18"                                 |

\* Not illustrated. √ Recommended parts.

## 2.13 Auto Intermittent Filtration Components

### 2.13.1 LOV™ Indicator Light and MIB (Manual Interface Board) Assembly

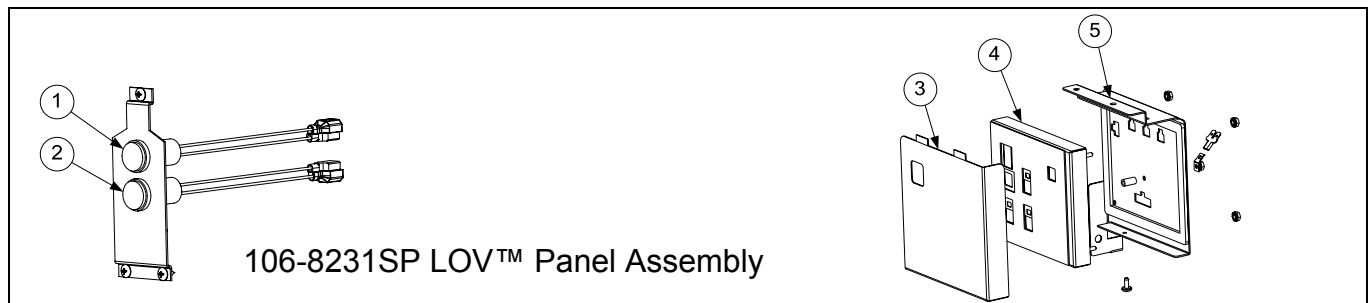

| ITEM | PART #     | COMPONENT   |
|------|------------|---|
| 1    | 106-8106SP | Light, Blue 24VDC LED Flush                                     |
| 2    | 106-8105SP | Light, Yellow 24VDC LED Flush                                   |
| 3    | 220-6554   | Cover, MIB  |
| √ 4  | 108-2158SP | Assembly, MIB Computer w/ Metalwork ( use 807-4481 for overlay) |
| 5    | 106-9999   | Assembly Back, Box MIB  |

√ Recommended parts.

### 2.13.2 AIF (Automatic Intermittent Filtration) Linear Actuator Board Assembly and ATO (Auto Top-Off) Components

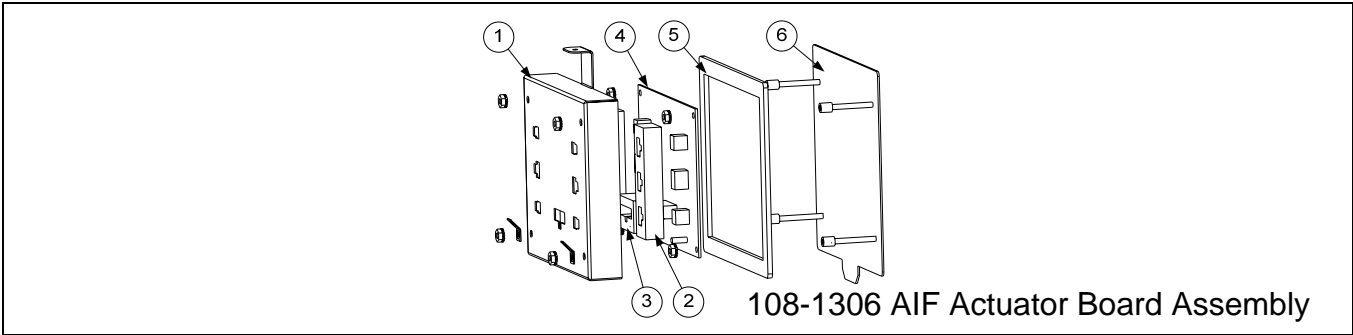

| ITEM | PART #   | COMPONENT                     |
|------|----------|-------------------------------|
| √    | 108-1306 | AIF Assembly                  |
| 1    | 824-1991 | Cover, Linear Actuator Board  |
| 2    | 816-0814 | Gasket, Linear Actuator Board |
| 3    | 816-0815 | Gasket, Computer Board        |
| 4    | 108-1304 | Board, AIF Linear Actuator    |
| 5    | 816-0820 | Seal, Linear Actuator Board   |
| 6    | 108-0097 | Box, Linear Actuator Stud     |

√ Recommended parts.

### 2.14 ATO (Auto Top-Off) Components

#### 2.14.1 JIB Cradle, JIB Cap/ Pick-Up Assembly and ATO Board Assemblies

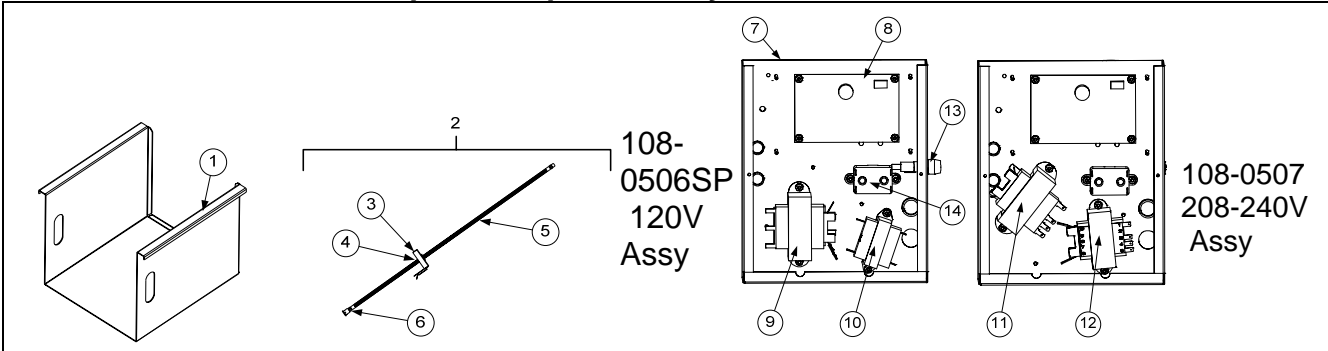

| ITEM | PART #     | COMPONENT   |
|------|------------|---|
| 1    | 220-3647   | Cradle, JIB Gas LOV™  |
| 2    | 108-1049SP | Cap, JIB Assembly   |
| 3    | 823-7575   | Cap, JIB  |
| 4    | 810-3664   | Bushing, Heyco  |
| 5    | 810-3663   | Hose, JIB   |
| 6    | 810-3300   | Inlet, Oil Reservoir Tube   |
| 7    | 108-0653   | Box, Assembly Auto Top Off Board ( used 220-5679 for ATO Box Cover) |
| √ 8  | 108-1279   | PCB Board, Automatic Top Off  |
| √ 9  | 807-2181   | Transformer, 100-120V/24V 62VA                                      |
| √ 10 | 807-0855   | Transformer, 120V 50/60-12V 20VA                                    |
| √ 11 | 807-2180   | Transformer, 208-240V/24V 50VA                                      |
| √ 12 | 807-2191   | Transformer, 208/230/240 -12V 30VA                                  |
| 13   | 807-1321   | Holder, Fuse AGC Panel Mount ¼"                                     |
| √ *  | 807-1597   | Fuse, 3A Slow-Blow  |
| √ 14 | 807-0012   | Relay, 18AMP 1/3 HP 24V Coil (Top off pump)                         |

\* Not illustrated. √ Recommended parts.

**NOTE:** Top off boxes for vats 4 and 5 have either item 9 or item 11, both have item 8.

## 2.14.2 ATO Pump Assembly

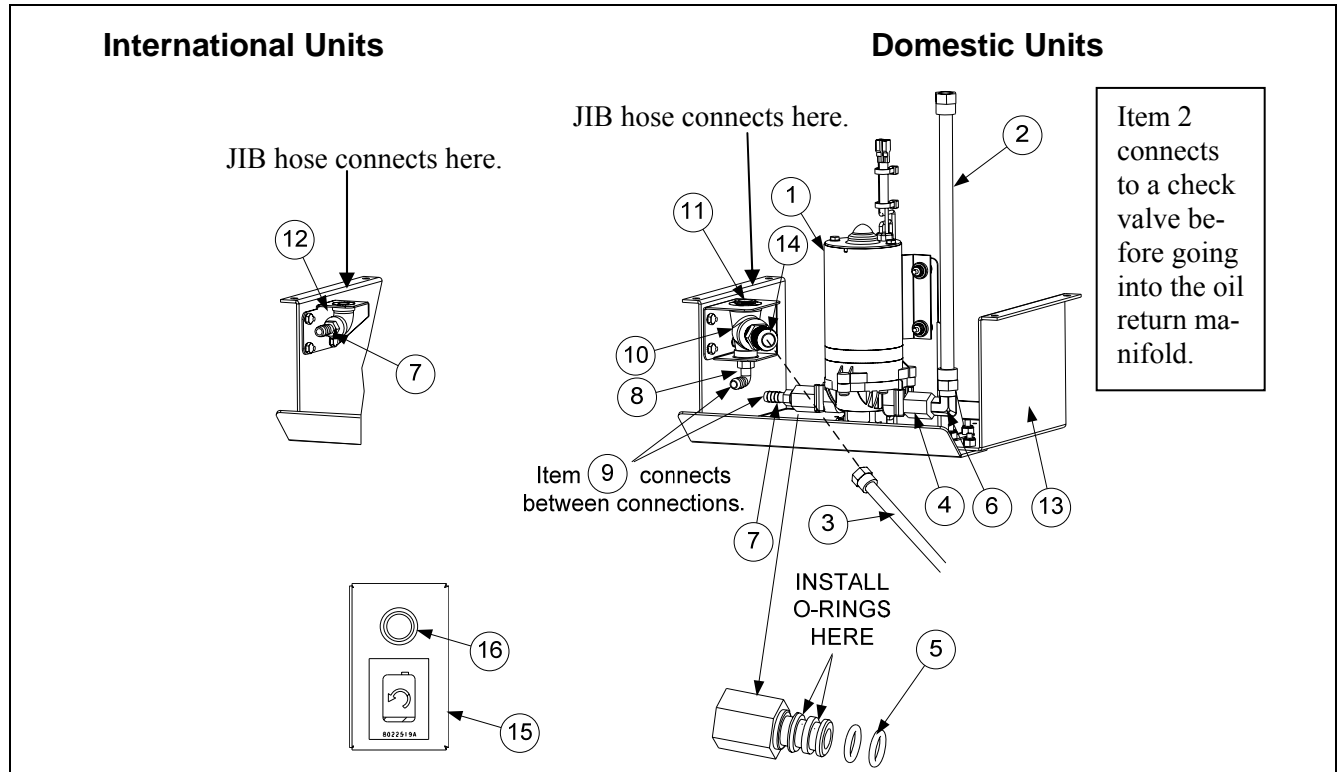

| ITEM | PART #   | COMPONENT  |
|------|----------|--|
| √ 1  | 108-0639 | Pump, Shurflo 24VAC  |
| 2    | 810-3263 | Flexline, ½" OD x 36-inch (Out to oil check valve and to return manifold)                        |
|      | 810-3375 | Flexline, ½" OD x 17-inch (Out to oil check valve and to return manifold) Two battery only)      |
| *    | 810-0667 | Check valve, ½ NPT 1 PSI   |
| 3    | 810-1069 | Flexline, ⅝" OD x 29.5-inch 2-Battery(In from RTI fresh oil solenoid) Domestic units only        |
|      | 810-3669 | Flexline, ⅝" OD x 45-inch 3, 4 and 5-Battery(In from RTI fresh oil solenoid) Domestic units only |
| 4    | 810-3666 | Fitting, Shurflo Pump  |
| 5    | 816-0782 | O-Ring, Viton #111   |
| 6    | 813-0940 | Elbow, ¼" NPT x ⅜ Flare  |
| 7    | 810-3770 | Fitting, ¼" NPT Male Barb  |
| *    | 816-0710 | Fitting, ¼" NPT x ½ Barb 90°   |
| 8    | 816-0710 | Fitting, Elbow ¼" NPT x ½" Barb  |
| 9    | 811-1139 | Hose, Silicone Braided 5"  |
| 10   | 823-7380 | Bracket W/A, RTI Gas JIB Connection  |
| 11   | 813-0304 | Bushing, ½" x ¼" BM Flush  |
| 12   | 823-7167 | Bracket W/A, GL 30 JIB Connection  |
| 13   | 108-2234 | Stud Assy, 2 Battery Topoff Tray   |
|      | 108-2238 | Stud Assy, 3, 4, and 5 Battery Topoff Tray   |
| 14   | 810-1668 | Adaptor, Male ⅝" OD x ½"   |
| 15   | 106-9206 | Assembly, JIB Reset Button Bracket   |
| 16   | 807-4678 | Switch, Momentary JIB Reset  |

\* Not illustrated.

√ Recommended parts.

### 2.14.3 ATO Pump Assembly Service Kit (Larger Top Off Lines)

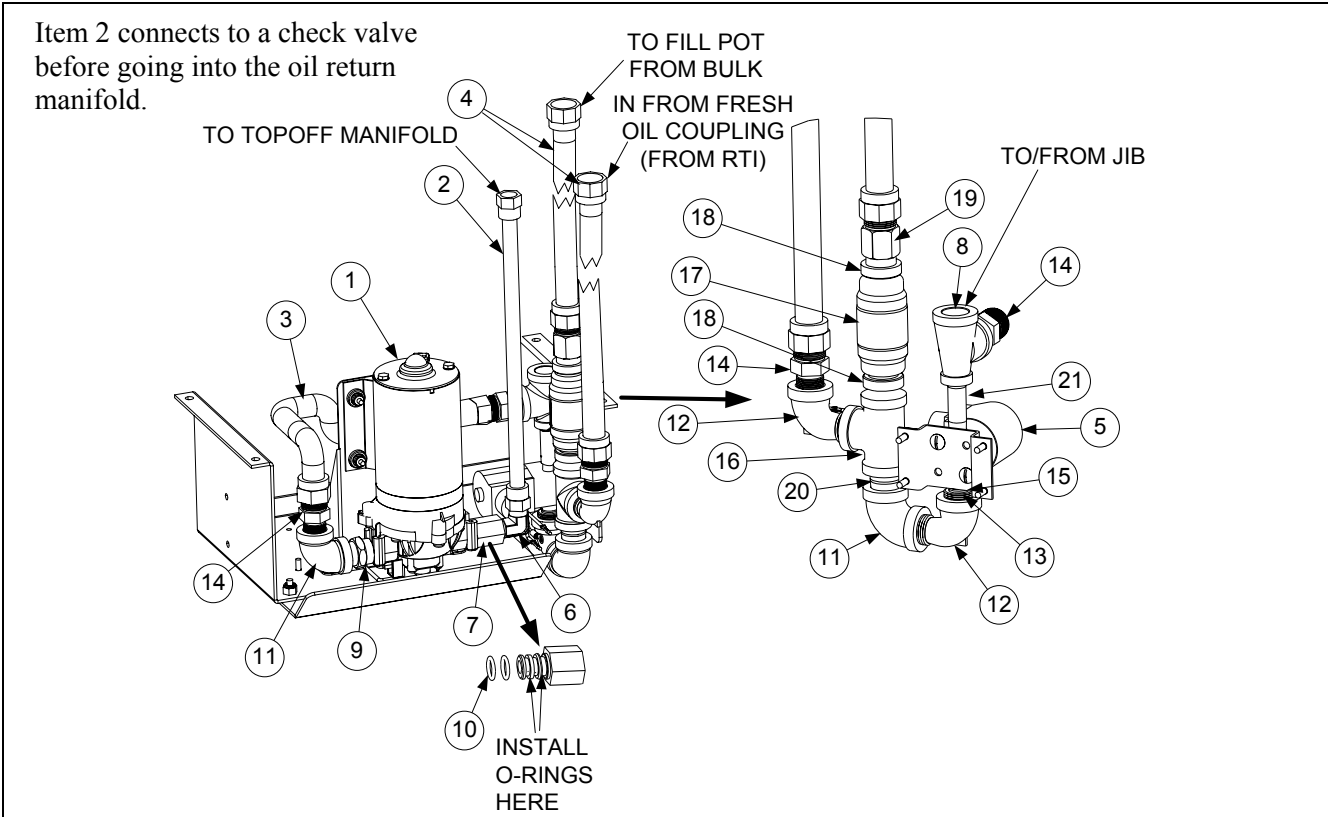

| ITEM | PART #   | COMPONENT   |
|------|----------|---|
|      | 108-3392 | Pump, Assy GL230 RTI ATO (use 108-3447 for GL330 RTO ATO)                               |
| √ 1  | 108-0639 | Pump, Shurflo 24VAC   |
| 2    | 810-3263 | Flexline, 1/2" OD x 36-inch (Out to oil check valve and to return manifold)             |
|      | 810-3375 | Flexline, 1/2" OD x 17-inch (Out to oil check valve and to return manifold) Two battery |
| *    | 810-0667 | Check valve, 1/2 NPT 1 PSI  |
| 3    | 810-1055 | Flexline, 5/8" OD x 11.50-inch (Inlet to Top Off Pump) Domestic units only              |
| 4    | 810-1369 | Flexline, 5/8" OD x 17.50-inch  |
| 5    | 106-6830 | Solenoid  |
| 6    | 813-0940 | Elbow, 1/4" NPT x 3/8 Flare   |
| 7    | 108-3403 | Fitting, Shurflo Connect  |
| 8    | 813-0530 | Tee, Reducing 1/2" x 1/4" x 1/2" (JIB hose connects here)                               |
| 9    | 108-2054 | Fitting Assy, Shurflo Connect   |
| 10   | 816-0782 | O-Ring, Viton #111  |
| 11   | 813-0062 | Elbow, 1/2" BM 90°  |
| 12   | 813-0165 | Elbow, Street 1/2" x 1/2" NPT 90° BM  |
| 13   | 813-0304 | Bushing, BM Flush   |
| 14   | 810-1668 | Adaptor, Male 5/8" OD x 1/2"  |
| 15   | 813-0838 | Nipple, 1/4" NPT BM Close   |
| 16   | 813-0003 | Tee, 1/2" x 1/2" x 1/2" BM  |
| 17   | 810-3583 | Check Valve 1/2" NPT 4 PSI  |
| 18   | 810-3738 | Adapter, Check Valve Close NPT  |
| 19   | 810-1669 | Adapter, Female 3/8" OD x 1/2"  |
| 20   | 813-0022 | Nipple, 1/2" x Close NPT BM   |
| 21   | 813-0537 | Nipple, 1/4" x 2.00" NPT  |

\* Not illustrated.

√ Recommended parts.

## 2.14.4 Shortening Melting Unit

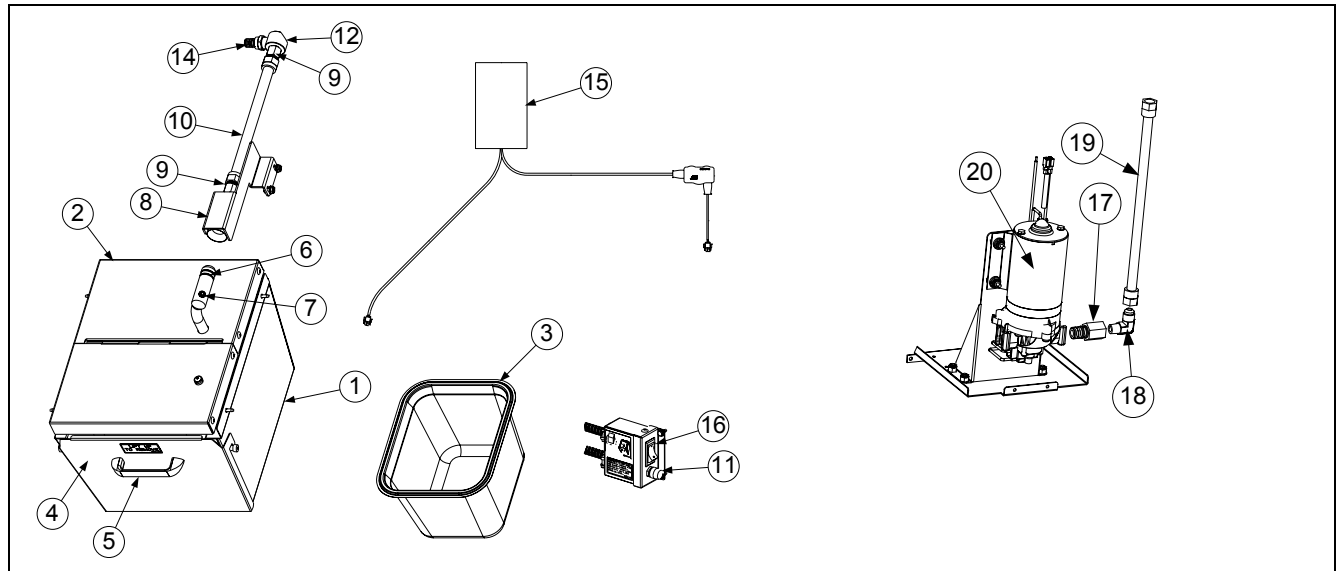

| ITEM | PART #   | COMPONENT  |
|------|----------|--|
|      | 108-3406 | Assembly, Heated Shortening                              |
| 1    | 108-2983 | Box Assembly, Heated Shortening                          |
| 2    | 108-3001 | Assembly, Heated Shortening Lid                          |
| 3    | 810-3957 | Pan, Heated Shortening                                   |
| 4    | 108-3372 | Cover, Shortening Box Front                              |
| 5    | 810-0180 | Handle   |
| √ 6  | 826-1392 | O-Ring (Pkg. of 5)                                       |
| 7    | 813-0568 | Plug, 1/8-inch Socket Head Pipe                          |
| 8    | 823-8079 | Bracket W/A, Shortening Suction 3 battery                |
|      | 823-8147 | Bracket W/A, Shortening Suction 4 battery                |
| 9    | 810-1669 | Adaptor, Female 7/8" OD x 1/2"                           |
| 10   | 810-1055 | Flexline, 5/8" OD x 11.5-inch                            |
| 11   | 807-1321 | Holder, Fuse   |
| √ *  | 807-1555 | Fuse 5 Amp   |
| 12   | 813-0908 | Adapter, 1/2" NPT 90°                                    |
| 13   | 810-3820 | Fitting, Quick Connect Shurflo Pump                      |
| 14   | 816-0782 | O-Ring, Viton #111                                       |
| 15   | 807-5268 | Strips, Hot Box Heater with controller                   |
| 16   | 807-4036 | Switch   |
| *    | 807-1098 | Heater Strip Assembly, 240V, 25W 18"                     |
| *    | 807-1419 | Heater Strip Assembly, 240V, 45W 36"                     |
| *    | 807-1473 | Heater Strip Assembly, 240V, 70W 56"                     |
| 17   | 810-3578 | Fitting, LOV Shurflo Pump                                |
| *    | 816-0782 | O-Ring, Viton #111                                       |
| 18   | 813-0940 | Elbow, 1/4" NPT x 3/8 Flare                              |
| 19   | 810-3375 | Flexline, 1/2" OD x 17-inch (Out to oil return manifold) |
| 20   | 108-0639 | Pump, Shurflo 24VAC                                      |

\* Not illustrated. √ Recommended parts.

## 2.15 RTI System Components

### 2.15.1 RTI Dispose Waste Valve and Test Box

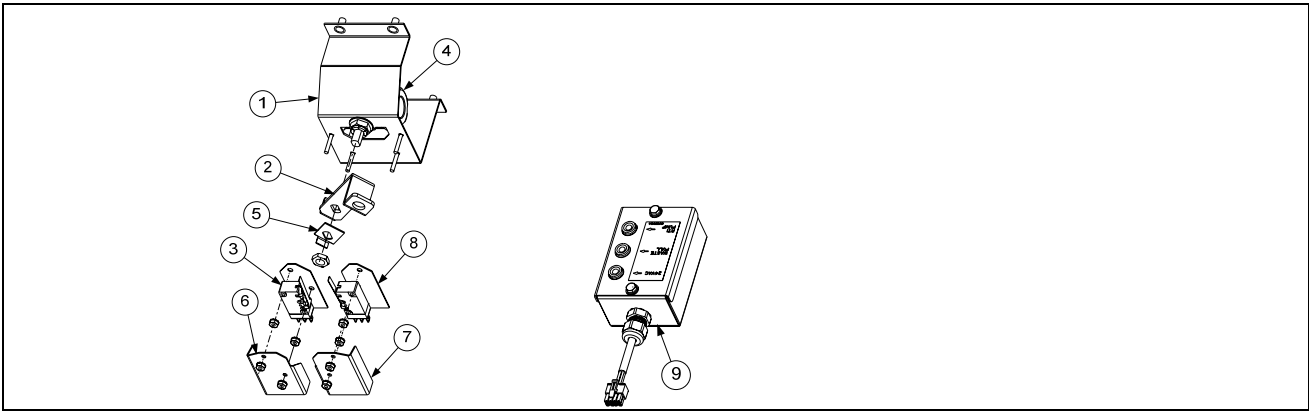

| ITEM | PART #   | COMPONENT                  |
|------|----------|----------------------------|
|      | 108-1433 | Valve, RTI Dispose Waste   |
| 1    | 108-1437 | Bracket, RTI Waste Valve   |
| 2    | 220-5899 | Handle, RTI Waste Valve    |
| 3    | 807-4936 | Microswitch, Gold Sealed   |
| 4    | 810-0278 | Valve, 1/2" Ball           |
| 5    | 900-2935 | Retainer, Nut Return Valve |
| 6    | 901-2348 | Cover, DV Safety Switch    |
| 7    | 902-2348 | Cover, DV Safety Switch    |
| 8    | 816-0220 | Insulation, RF Switch      |
| 9    | 108-0716 | Box, LOV™ RTI Test         |

### 2.15.2 RTI Manifold and Accessories Prior to Oct. 2010

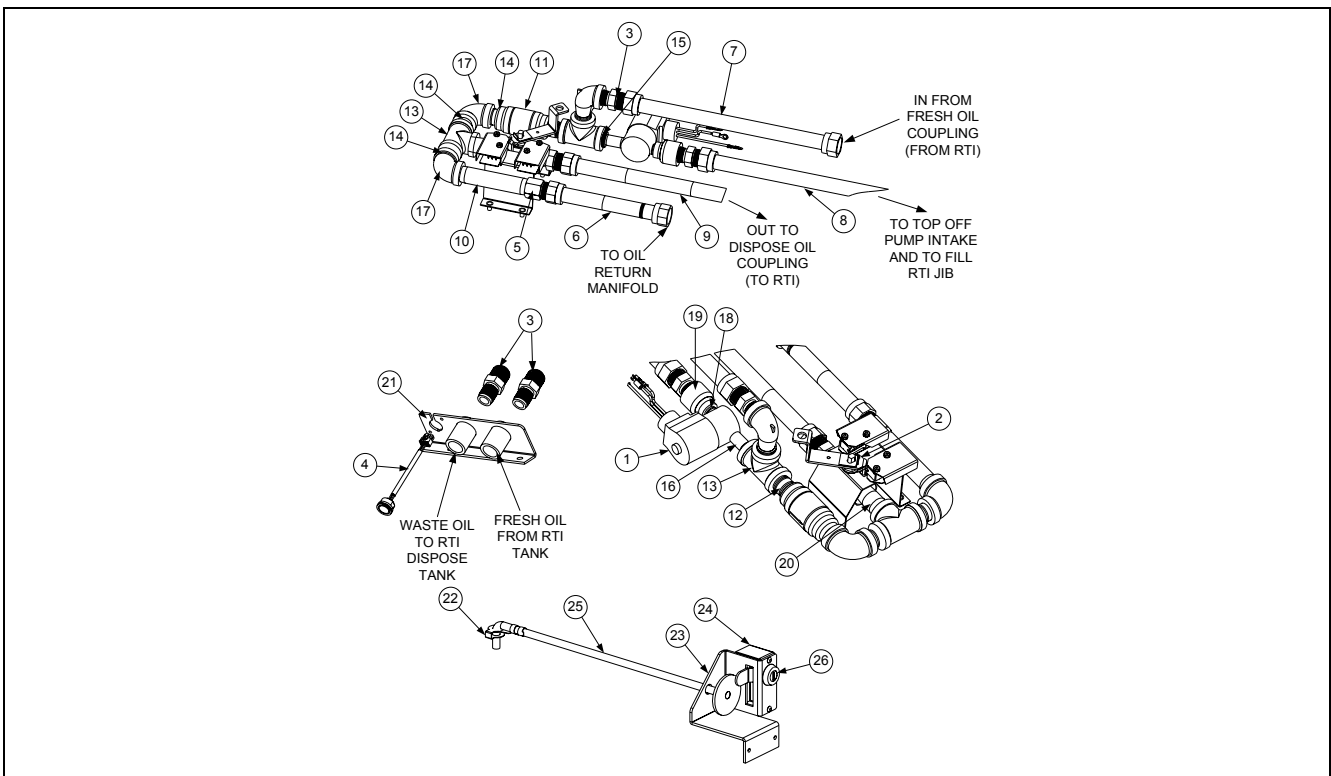

## 2.15.2 RTI Manifold and Accessories prior to Oct 2010 cont.

| ITEM | PART #     | COMPONENT  |
|------|------------|--|
| √ 1  | 106-6830   | Solenoid Assembly  |
| 2    | 108-1433   | Valve, RTI Waste Assembly (see page 2-29 for parts)                              |
| 3    | 810-1668   | Adaptor, Male 5/8" OD x 1/2"   |
| 4    | 807-4760   | Harness, RTI – MIB connection  |
| 5    | 810-1669   | Adaptor, Female 7/8" OD x 1/2"   |
| 6    | 810-1680   | Flexline, 5/8" OD x 6.50-inches long ( <i>used on 3, 4 and 5 battery units</i> ) |
|      | 810-1055   | Flexline, 5/8" OD x 29-inches long ( <i>used on 2 battery units</i> )            |
| 7    | 810-1055   | Flexline, 5/8" OD x 11.50-inches long  |
| 8    | 810-3669   | Flexline, 5/8" OD x 45-inches long ( <i>used on 3, 4 and 5 battery units</i> )   |
|      | 810-1069   | Flexline, 5/8" OD x 29-inches long ( <i>used on 2 battery units</i> )            |
| 9    | 810-1057   | Flexline, 5/8" OD x 13-inches long   |
| 10   | 813-0251   | Nipple, 1/2" x 4.50-inches NPT BM ( <i>used on 3, 4 and 5 battery units</i> )    |
| 11   | 810-3583   | Valve, Check 1/2" NPT 4 PSI RTI Manifold   |
| 12   | 813-0087   | Nipple, 1/2" x 1.50-inches NPT BM  |
| 13   | 813-0003   | Tee, 1/2" x 1/2" x 1/2" BM   |
| 14   | 810-3738   | Adaptor, Check Valve Close Nipple  |
| 15   | 813-0304   | Bushing, 1/2" x 1/4"   |
| 16   | 813-0571   | Nipple, 1/4" x 1.50-inches NPT BM  |
| 17   | 813-0062   | Elbow, 1/2" BM 90°   |
| 18   | 813-0838   | Nipple, 1/4" NPT   |
| 19   | 813-0555   | Reducer, Bell Fitting, 1/2" to 1/4" NPT BM                                       |
| 20   | 813-0298   | Nipple, 1/2" x 2-inches NPT BM   |
| 21   | 823-7205   | Bracket W/A, Gas LOV™ RTI  |
|      | 108-0686SP | Handle and Lock Assy, Gas LOV™ RTI   |
| 22   | 809-0657   | Clip, Clevis Right Rod End   |
| 23   | 220-5656   | Brace, RTI Handle  |
| 24   | 220-5657   | Cover, RTI Handle  |
| 25   | 823-7208   | Handle, Gas LOV™ RTI Waste Pull  |
| 26   | 810-3587   | Lock, RTI Waste Handle (includes keys)   |

√ Recommended parts.

### 2.15.3 RTI Manifold and Accessories after Oct. 2010

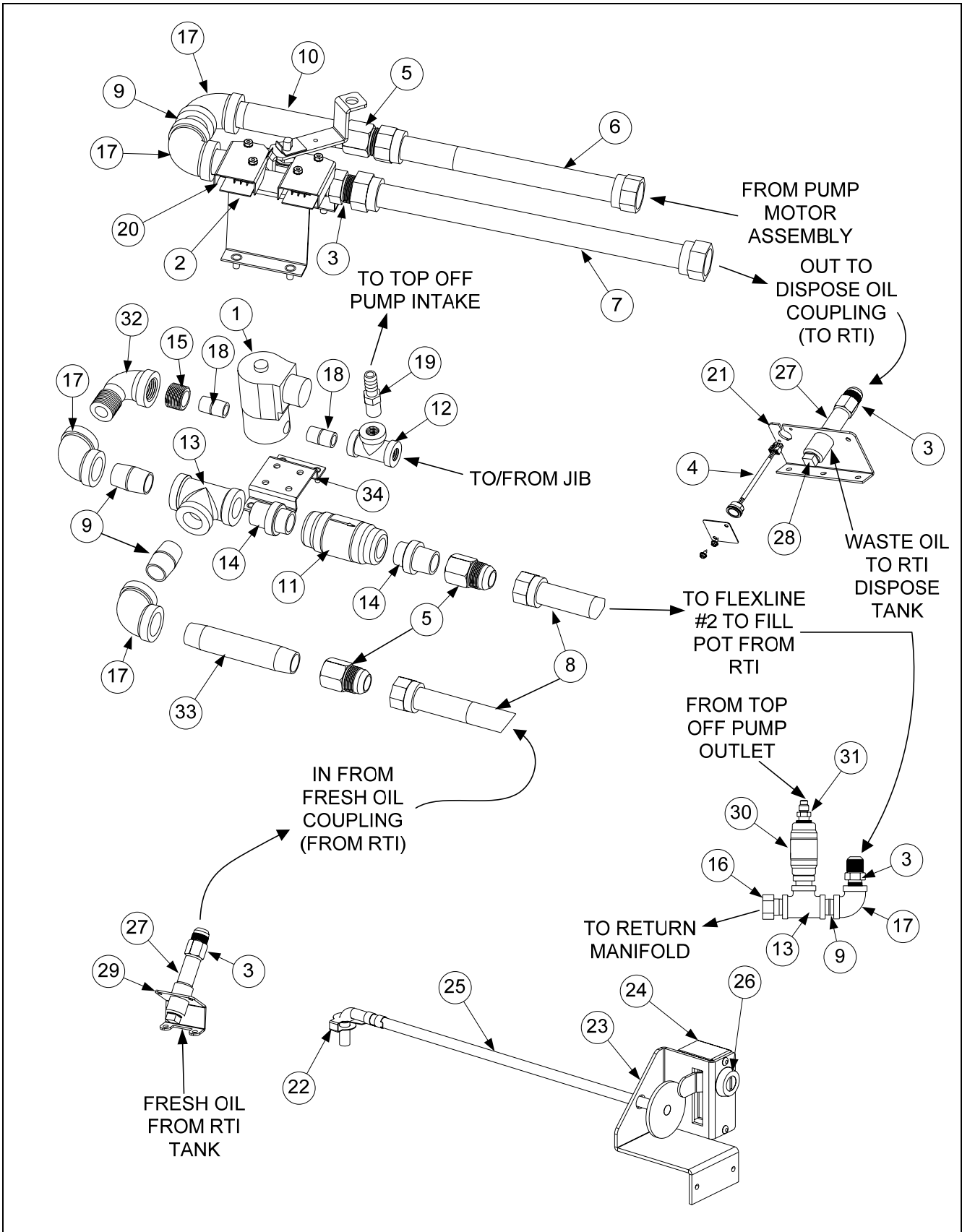

### 2.15.3 RTI Manifold and Accessories after Oct 2010 cont.

| ITEM | PART #     | COMPONENT  |
|------|------------|--|
| √ 1  | 106-6830   | Solenoid Assembly  |
| 2    | 108-1433   | Valve, RTI Waste Assembly (see page 2-29 for parts)                              |
| 3    | 810-1669   | Adaptor, Male 5/8" OD x 1/2"   |
| 4    | 807-4760   | Harness, RTI – MIB connection  |
| 5    | 810-1669   | Adaptor, Female 7/8" OD x 1/2"   |
| 6    | 810-1067   | Flexline, 5/8" OD x 8.50-inches long ( <i>used on 3, 4 and 5 battery units</i> ) |
|      | 810-1057   | Flexline, 5/8" OD x 13-inches long ( <i>used on 2 battery units</i> )            |
| 7    | 810-1055   | Flexline, 5/8" OD x 11.50-inches long  |
| 8    | 810-1369   | Flexline, 5/8" OD x 17.50-inches long  |
| 9    | 813-0022   | Nipple, 1/2" x Close NPT BM  |
| 10   | 813-0251   | Nipple, 1/2" x 4.50-inches NPT BM ( <i>used on 3, 4 and 5 battery units</i> )    |
| 11   | 810-3583   | Valve, Check 1/2" NPT 4 PSI RTI Manifold   |
| 12   | 813-0958   | Tee, 1/4" NPT BM   |
| 13   | 813-0003   | Tee, 1/2" x 1/2" x 1/2" BM   |
| 14   | 810-3738   | Adaptor, Check Valve Close Nipple  |
| 15   | 813-0304   | Bushing, 1/2" x 1/4"   |
| 16   | 810-3160   | Adaptor, 1/2" NPT x 15/16"   |
| 17   | 813-0062   | Elbow, 1/2" BM 90°   |
| 18   | 813-0838   | Nipple, 1/4" NPT   |
| 19   | 816-0708   | Fitting, 1/4" NPT Male Barb  |
| 20   | 813-0298   | Nipple, 1/2" x 2-inches NPT BM   |
| 21   | 823-7863   | Bracket W/A, Gas LOV™ RTI Dispose  |
|      | 108-0686SP | Handle and Lock Assy, Gas LOV™ RTI   |
| 22   | 809-0657   | Clip, Clevis Right Rod End   |
| 23   | 220-5656   | Brace, RTI Handle  |
| 24   | 220-5657   | Cover, RTI Handle  |
| 25   | 823-7208   | Handle, Gas LOV™ RTI Waste Pull  |
| 26   | 810-3587   | Lock, RTI Waste Handle (includes keys)   |
| 27   | 813-0265   | Nipple, 1/2" x 2.50-inches NPT BM  |
| 28   | 813-0336   | Plug, 1/2" NPT SQ HD SS  |
| 29   | 823-7838   | Bracket W/A, Gas LOV™ RTI Fresh Oil  |
| 30   | 810-0667   | Valve, Check 1/2" NPT 1 PSI RTI Manifold   |
| 31   | 810-3270   | Fitting, 3/8" Flare x 1/4" NPT   |
| 32   | 813-0165   | Elbow, ST 1/2" NPT 90° BM  |
| 33   | 813-0093   | Nipple, 1/2" x 4-inches NPT BM   |
| 34   | 108-2192   | Stud Assy, GL Solenoid Bracket   |

√ Recommended parts.



Frymaster, L.L.C., 8700 Line Avenue, Shreveport, Louisiana 71106

TEL 1-318-865-1711 FAX (Parts) 1-318-219-7140 FAX (Tech Support) 1-318-219-7135

PRINTED IN THE UNITED STATES

SERVICE HOTLINE  
1-800-551-8633

819-6316  
SEP 2011